

金轮牌工业用缝纫机

GOLDEN WHEEL INDUSTRIAL SEWING MACHINE

使用說明書

INSTRUCTION MANUAL



CS-810



CS-820

启翔股份有限公司

CHEE SIANG INDUSTRIAL CO., LTD.

INSTRUCTION MANUAL FOR POST-BED INDUSTRIAL SEWING MACHINE.

This manual is prepared to permit the sewing machine to be used efficiently and for highest performance.

This machine is post-bed industrial sewing machine suitable for sewing shoes, bags, caps and general leather works. You can either select 1-needle or 2-needle machine according to your type of works.

Being equipped with spring return reverse lever type feed mechanism opener type vertical hook, and slide type thread take-up provides perfect uniformed stitching.

— I N D E X —

Specification	2
Main parts name of machine head	3
Preparation for installation of machine	4
1). Place of installation of machine	4
2). How to mount the machine head	4
3). How to mount the motor	4
4). How to connect the motor lever and foot pedal.	4
5). How to mount the bobbin winder assembly	4
6). How to mount and adjust the knee lifter mechanism	5
7). How to mount the oil pan	6
8). How to mount the vibration preventing rubber	6
II. Preparation for operation	7
1). Selection of thread	7
2). How to attach the needle	7
3). How to lead the upper thread	8
4). How to wind the lower thread on the bobbin	9
5). How to adjust the bobbin winder assembly	10
6). How to place the bobbin into the hook	11
III. How to operate	13
1). Starting to sewing	13
2). Sewing over	13
IV. Stitching adjustment	14
1). Adjustment of stitch length	14
2). Forward and Reverse stitching	14
3). Adjustment of thread tension	14
4). Adjustment of feed dog height and pressure of presser on materials	17
5). Proper timing between the hook and needle	18
6). Proper timing between the hook and opener	21
7). Proper timing between the feed dog and needle	22
V. Cleaning and Lubrication	23
1). Cleaning	23
2). Lubrication	23
3). Grease	24

* **Specification and main parts name of machine head.**

■ **SPECIFICATIONS**

Application	Shoes, Bags, Caps, and leather works.	Hook	Vertical hook with opener
Max. speed	3000 SPM.	Stitch length adjustment . . .	Dial regulator type
Needle	DP x 5 (135 x 5)	Reverse stitching	Spring return manual tacker
Needle bar stroke . . .	33.4mm (1 - 5/16")	Post height	178 mm (7")
Thread take up	Slide type	Lubrication	Manual oiling, provided with two oil reservoir at arm
Stitch length	0 ~ 5mm (0~3/16")	Oil circulation	Automatic capillary action with oil wicks
Presser foot stroke . .	Knee lifter 10mm, Hand 7.2mm	Knee mechanism	Lever system
Presser foot	one-needle . . . Roller foot	Table	"DN" type
	two-needle (1/16") Roller foot	Motor	Clutch motor (400W)
	two-needle (1/4") Usual foot		

■ **Main parts name of machine head**

CS-810

(One-Needle Type)

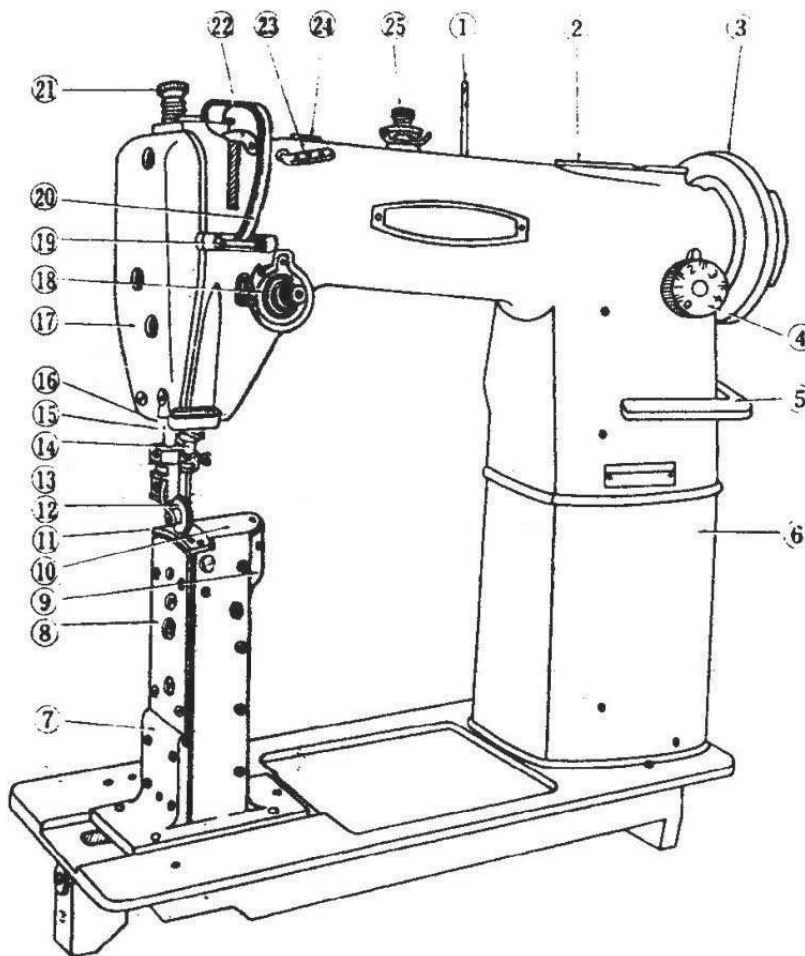

- | | |
|----------------------------------|--|
| (1) Spool pin | (14) Needle bar |
| (2) Oil reservoir (right) | (15) Thread guide (needle bar bushing) |
| (3) Balance wheel | (16) Presser bar |
| (4) Stitch regulating dial | (17) Face plate |
| (5) Reverse lever | (18) Thread tension regulator |
| (6) Post | (19) Thread guide (arm) |
| (7) Hook post holder | (20) Thread take up lever guard |
| (8) Hook post cover plate (back) | (21) Presser regulating thumb screw |
| (9) Hook shaft bracket | (22) Thread take up lever |
| (10) Slide plate | (23) Thread retainer |
| (11) Needle plate | (24) Oil reservoir (left) |
| (12) Roller foot | (25) Pre-tension |
| (13) Thread guide (needle bar) | |

CS-820

(Two-Needle Type)

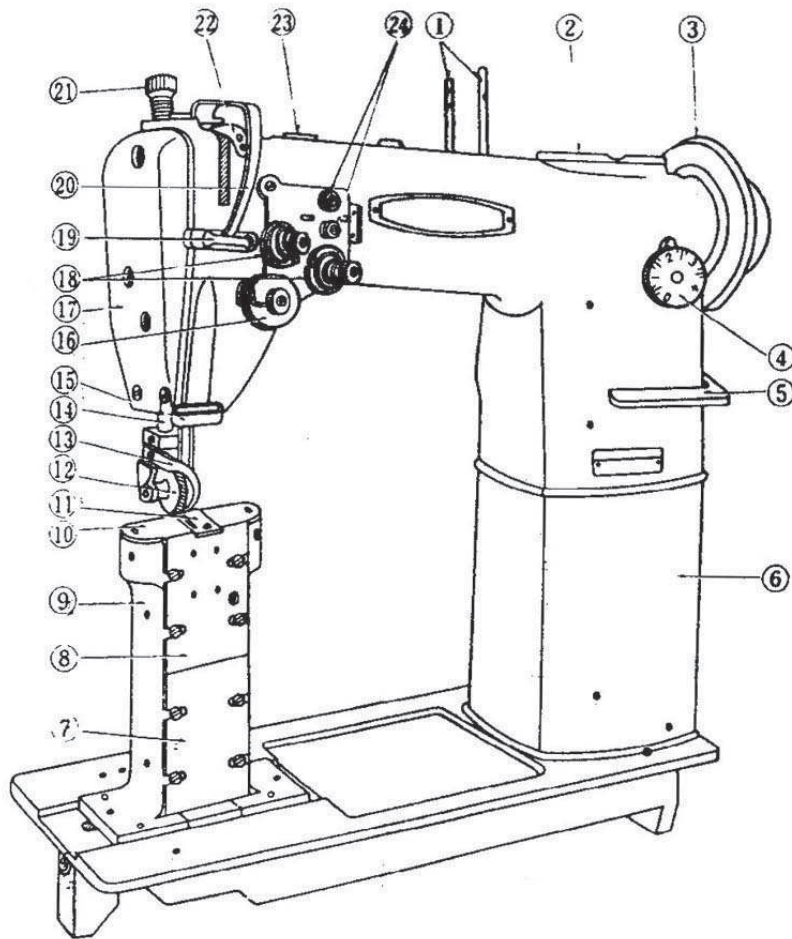

- | | | |
|-----------------------------------|-----------------------------|-------------------------------------|
| (1) Spool pin | (9) Hook shaft bracket | (17) Face plate |
| (2) Oil reservoir (right) | (10) Slide plate | (18) Thread tension regulator |
| (3) Balance wheel | (11) Needle plate | (19) Thread guide (upper) |
| (4) Stitch regulating dial | (12) Roller foot | (20) Thread take up lever guard |
| (5) Reverse lever | (13) Needle guide | (21) Presser regulating thumb screw |
| (6) Post | (14) Presser bar | (22) Thread take up lever |
| (7) Hook post cover plate (lower) | (15) Thread guide (lower) | (23) Oil reservoir (left) |
| (8) Hook post cover plate (upper) | (16) Thread controller disc | (24) Pre-tension |

* Preparation for installation of machine head

I PREPARATION FOR INSTALLATION OF MACHINE HEAD

1. PLACE OF INSTALLATION OF MACHINE.

The machine should be installed on well-leveled floor in order to ensure smooth operating of your machine at high speed without vibration.

2. HOW TO MOUNT THE MACHINE HEAD ON TO THE TABLE.

Instal the hinge with screws, provided in accessory, at hole on the back of the bed and hook to the hinge plate of the table, then the head is set on the table.

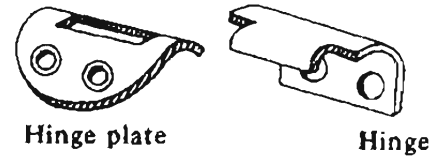

3. MOUNTING OF THE MOTOR.

- ◆ The motor is mounted generally with bolts, nuts, and washers as provided.
- ◆ Set the position so that the motor pulley and balance wheel grooves are aligned straight as shown in Fig. for proper operation when the belt is inserted.
- ◆ Then connect power supply cord and motor cord extened from switch.

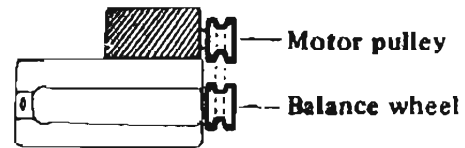

4. HOW TO CONNECT THE MOTOR LEVER AND FOOT PEDAL.

- ◆ The angle of the slope of the pedal can be important. It can make a difference in the strength necessary to press the pedal.
- ◆ There might be a slight difference in operator's posture, but generally 30° - 40° angle as shown in Fig. (A) is considered best.
- ◆ The treadle position shown in Fig. (B) will be difficult. In this case, adjust the length of the connecting rod to suit the operator.

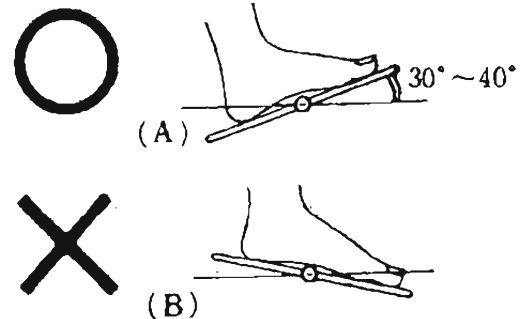

5. HOW TO MOUNT THE BOBBIN WINDER ASSEMBLY.

- ◆ Set the position of the bobbin winder assembly provided in accessory, to be in parallel with the belt hole of the table, with the lever pushed in operation position.
- ◆ When bobbin winder pulley will come in contact with the belt, fix the assembly onto the table with two screws provided, as shown in Fig.

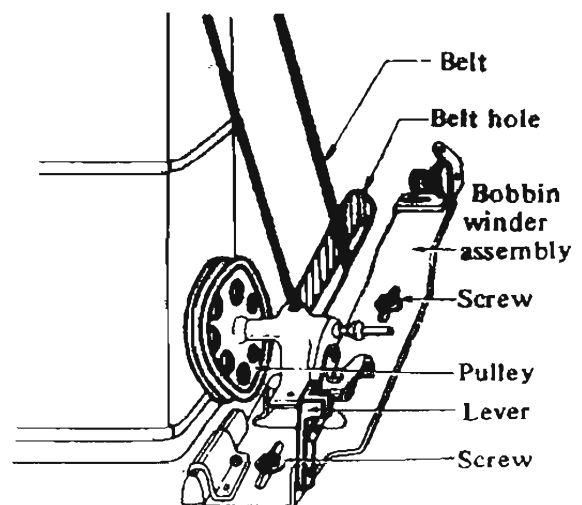

* Preparation for installation of machine head

6. HOW TO MOUNT AND ADJUST THE KNEE LIFTER MECHANISM.

- ◆ The knee lifter mechanism is employed to raise and lower the presser bar.
- ◆ Mount it properly onto the table by following method for easy operation.
- ◆ If improperly installed, the operating action will be heavy and tire the operator.

1) Place of mounting.

- ◆ Make a hole for knee lifter shaft bracket underneath the table according to Fig. shown.

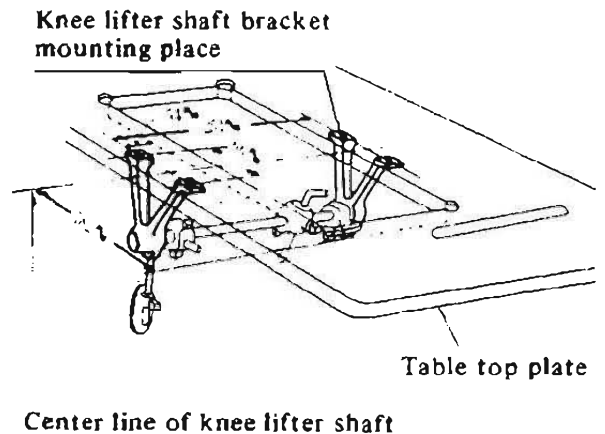

2) How to mount.

- (1) Mount the knee lifter shaft bracket while the side of hole for spring towards your side as shown in Fig.
- (2) The other side of the knee lifter shaft bracket is screwed so as able to insert the knee lifter shaft.
- (3) On the knee lifter shaft, mount the knee lifter position bracket, regulating rod bracket, knee plate bar bracket, and spring in the order mentioned, then tighten respectively.
- (4) Mount the knee lifter shaft, on which fixed respective parts, on the shaft bracket.
- (5) After checking up all the parts and inclination of the knee lifter shaft, tighten the shaft bracket screws.
- (6) The shorter side of knee plate bar is mounted on the bar bracket, and longer side of the bar is mounted on the knee plate.
- (7) The end of spring is inserted into a hole of the shaft bracket (front).
- (8) The other end of spring is placed on the knee plate bar moving it.
- (9) After mounting all these parts, check whether the knee lifter mechanism can be operated lightly.

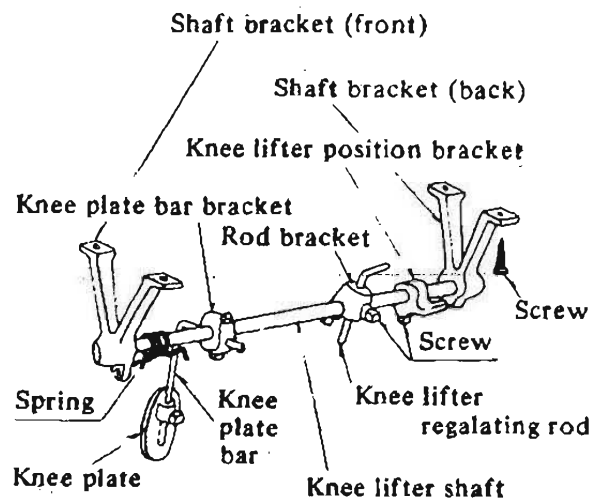

* Preparation for installation of machine head

3) Adjustment.

(1) Place of knee lifter position bracket.

Since the position bracket makes standardize the starting point of knee plate, tighten the screw at the proper position so that the stopper of position bracket come contact with top underneath of the shaft bracket (back).

(2) Position of the knee lifter bell crank regulating rod and its bracket.

- ◆ The regulating rod makes raise and down the presser foot by means of moving the bell crank lever up and down.
- ◆ While the presser foot downed, adjust the length (A) loosening the regulating rod screw so that the rod and crank lever contacts with as shown in Fig.

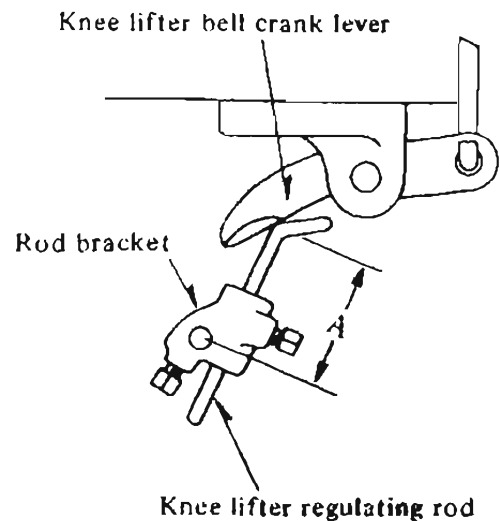

7. HOW TO MOUNT THE OIL PAN.

Fit the oil pan with nails into the hole bored in the table so as not to come into contact with the knee lifter mechanism.

8. HOW TO MOUNT THE VIBRATION PREVENTING RUBBER.

The vibration preventing rubber is used to prevent the machine from vibrating and thereby provide smooth operation of the machine. Fit these rubber insulators properly at the four corners of the table as shown in Fig. Remember, the machine will vibrate if these are not mounted properly.

(1) Hollow out four corners of the table 20mm radius and 13mm depth to fit the rubber insulators.

* Be sure to give smooth surface to "A" where hollow out is made.

(2) Nail the vibration preventing rubbers down at the four corners.

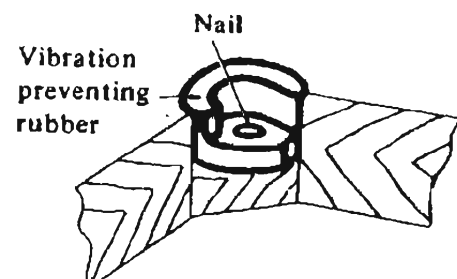
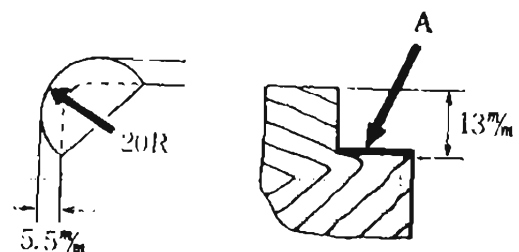

II. PREPARATION FOR OPERATION.

1. SELECTION OF THREAD.

- ◆ For best results, use high quality machine thread.
- ◆ For upper thread use left-twist thread.
- ◆ To check whether a thread is left-twist or right-twist, hold the thread as shown in Fig., and twist the thread held in the right hand toward your side. If the thread twist becomes loose, the thread is right-twist, and if the thread twist becomes tight the thread is left-twist.

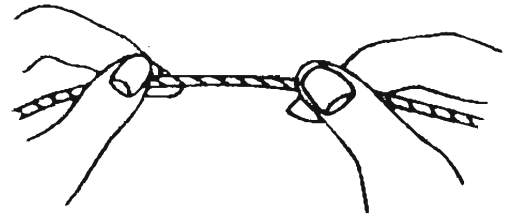

2. HOW TO ATTACH THE NEEDLE.

- ◆ DP x 5 (135 x 5) type needle is recommendable for general use.
- ◆ But select the needle size that meets the requirements of the materials sewn and the thread used.

For One Needle Type

- (1) While the presser bar lifter is raised, turn the balance wheel by hand to raise the needle bar to its highest position.
- (2) Move the roller foot to the left as shown in Fig.
- (3) Loosen the needle clamping screw.
- (4) Hold the needle to its side with the long groove side (left). Then insert the needle as deeply as it will go into the needle clamping hole.
- (5) Securely tighten the needle clamping screw.

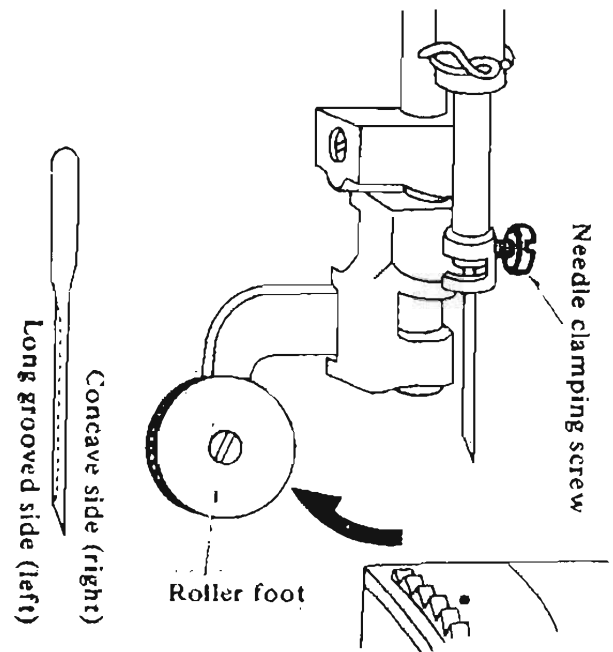

For Two Needle Type

- (1) While the presser bar lifter is raised, turn the balance wheel by hand to raise the needle bar to its highest position.
- (2) Move the roller foot to the left as shown in Fig.
- (3) Loosen the needle clamping screw.
- (4) Hold the needles so that the two needles side with the long grooved (faces each other), and insert it as deeply as it will go into the needle clamping holes.
- (5) Securely tighten the needle clamping screw.

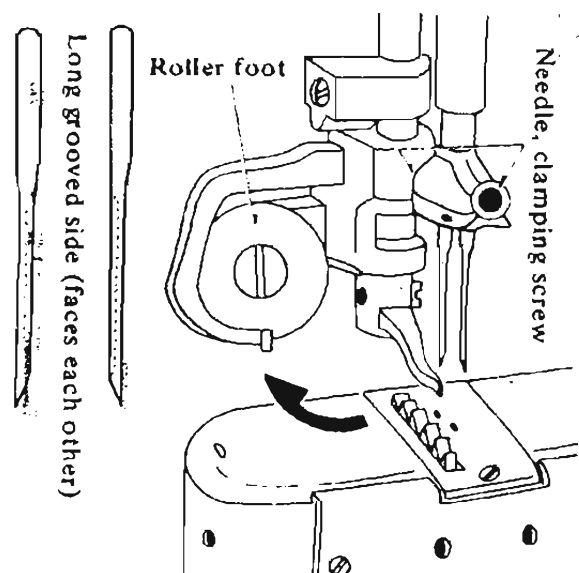

* Preparation for operation

- * When using nylon or silk threads, the loops may be formed improperly or stitch skipping may result due to the twist of these threads. In this case, observe the condition of the loops and mount the needle in a manner that the needle hole would be positioned in a slightly oblique direction.

Needle sectional plan

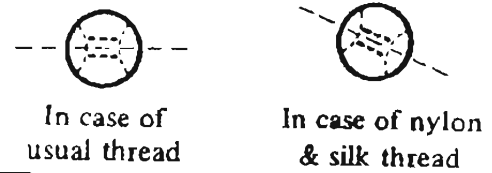

3. HOW TO THREAD THE UPPER THREAD.

For Needle Type

- (1) Raise the thread take up lever to its highest position turning the balance wheel by hand.
- (2) After the presser bar lifter is raised, move the roller foot to the left holding downward as per arrow shown in Fig.

(3) Thread in the following order:

- | | |
|-------------------------|-------------------------------------|
| 1 Spool pin | 8 Thread guide (Needle bar bushing) |
| 2 Pre-tension | |
| 3 Thread retainer | 9 Thread guide (needle bar) |
| 4 Tension discs | 10 Needle |
| 5 Thread take up spring | |
| 6 Thread guide (arm) | |
| 7 Thread take up | |
| 6 Thread guide (arm) | |

- * The spool pin 1 with cross-shaped hole, pre-tension 2 and thread retainer 3 are provided to prevent the thread from twisting, so follow as shown in Fig.
- * The tension discs 4 consists of two discs, pass the thread between these discs from the right to the left.
- * For the thread take up spring 5, pass the thread from the right to the left.
- * For the take up lever 7, pass it from the right to the left.
- * For the needle 10, pass it from the left to the right.

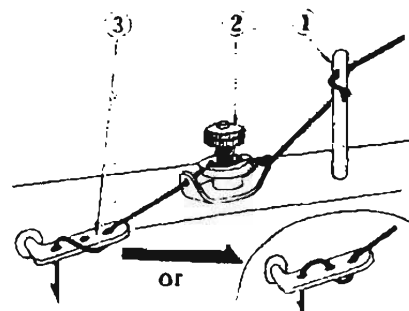
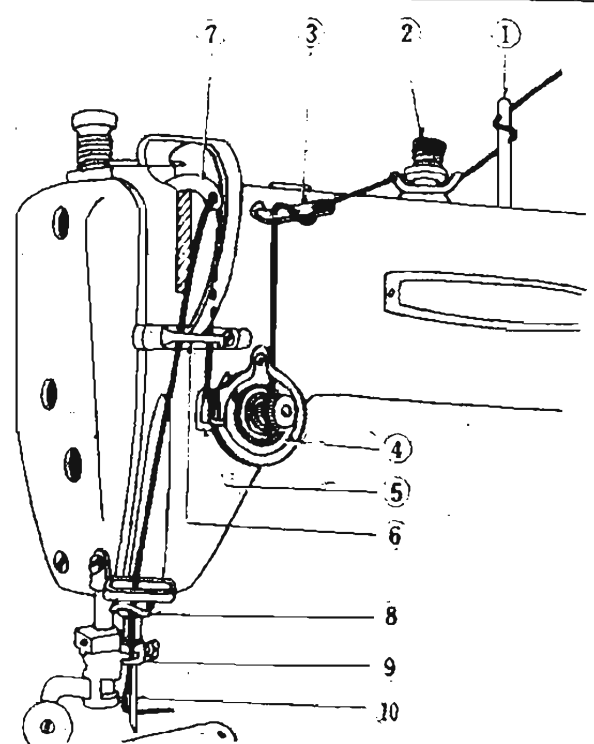
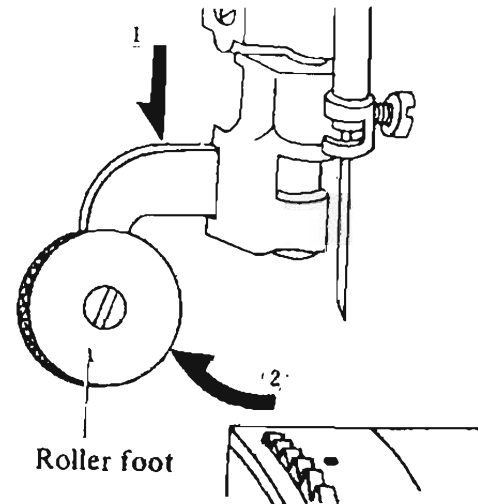

* Preparation for operation

In case of Two Needle Type

- (1) Raise the thread take up lever to its highest position turning the balance wheel by hand.
- (2) In case of the roller foot, it is same order as one needle type did - move the roller foot to the left.
- (3) How to thread from the cotton stand spool (left).

L1	Spool pin (left)	6	Thread take up spring
L2	Thread guide (Upper)	7	Thread guide (upper)
L2'	Thread guide pin (right)	L8	Take up lever (upper hole)
L3	Pre-tension (upper)	7	Thread guide (upper)
L3'	Thread guide pin (left)	9	Thread guide (lower)
L4	Thread tension regulator (upper)	L10	Needle clamping (back)
L5	Thread controller disc (back)	L11	Needle (left)

- (4) How to thread from the cotton stand spool (right).

R1	Spool pin (right)	7	Thread guide (upper)
R2	Thread guide (lower)	R8	Take up lever (lower hole)
R3	Pre-tension (lower)	7	Thread guide (upper)
R4	Thread tension regulator (lower)	9	Thread guide (lower)
R5	Thread controller disc (front)	R10	Needle clamping (front)
6	Thread take up spring	R11	Needle (right)

* To the pre-tension 3 and tension regulator 4 thread between these discs.

* To the two needles 11., thread from the inside to outside.

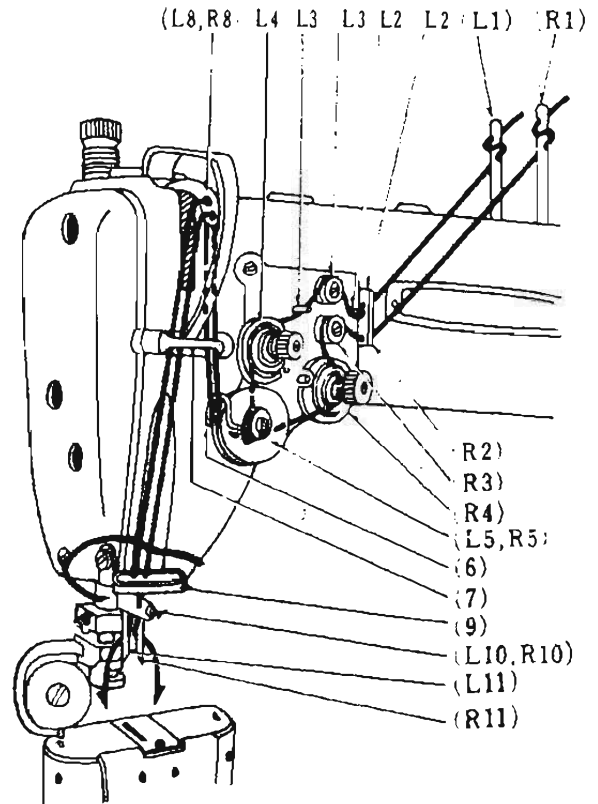

4. HOW TO WIND THE LOWER THREAD ON THE BOBBIN.

- (1) Thread from the spool through the hole of the thread guide 1 to the tension discs 2.
- (2) Wind the end of the thread through the tension discs 2 on the bobbin about 5 - 6 times.
- (3) Fit the bobbin into the bobbin pin 3 in a manner so that the thread can be wound on the bobbin from the underside.
- (4) Push the lever toward the other side so that the pulley and the belt will engage.
- (5) Operate the machine so that the thread can be wound on the bobbin.
- (6) The bobbin winder will automatically be free from the belt when the bobbin is fully wound with thread, and stopped.

* This operation can be done while working.

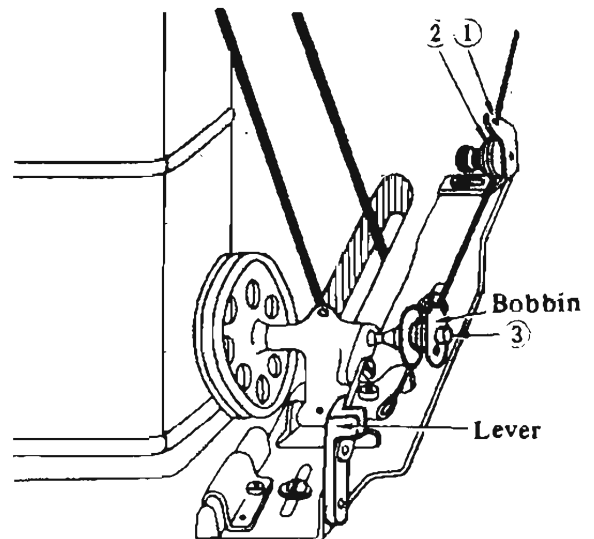

* Preperation for operation

5. HOW TO ADJUST THE BOBBIN WINDER ASSEMBLY.

- ◆ It is desirable that the bobbin is wound evenly with thread as shown in Fig. (A), but Fig. (B) & (C) shown are not proper winding.
- ◆ Adjust the bobbin winder assembly in the following order so as able to wind the thread onto the bobbin properly.

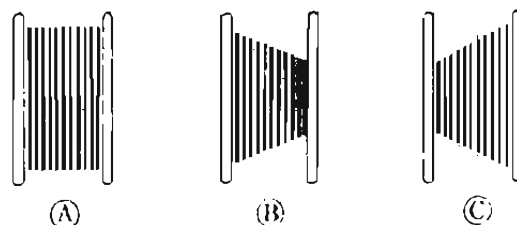

1) In case of uneven winding.

- ◆ In the event of uneven winding toward the left, loosen the screw (A) of the thread guide, and adjust it moving the thread guide slightly to the right.
- ◆ In the event of uneven winding toward the right, adjust it moving the guide to the left.
- ◆ After adjusted, tighten the screw (A) of the thread guide.

2) Winding strength of thread.

- ◆ When the thread (particularly nylon thread) is wound too tightly, there is a tendency to unwind the thread on a bobbin.
- ◆ In this case, adjust the pressure of tension discs with nut (B) so that thread can be pulled out smoothly.

3) Winding amount of thread.

- ◆ Best results are obtained when the bobbin is wound up to 4/5 of its full capacity with thread. Excessive winding will results in poor pull-out of the thread.
- ◆ In the event of excessive winding, turn the screw (C) to the left, and to the right when insufficient.

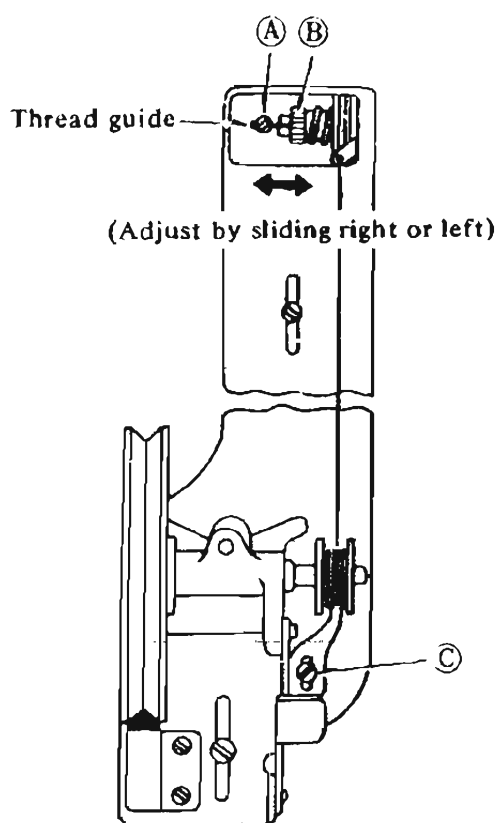

* Preparation for operation

6. HOW TO PLACE THE BOBBIN INTO THE HOOK.

In case of Needle Type

- (1) Raise the needle bar to its highest position turning the balance wheel by hand.
- (2) Move the roller foot to the left as shown in Fig.
- (3) Move the slide plate.
- (4) Turn up the latch lever as shown in Fig.
- (5) Pull the bobbin thread for about 5cm, hold it like in the illustration.
- (6) Fit the bobbin, into the hook base.
- (7) Flap down the latch lever.
- (8) Insert the pulled out thread end through the slit (1) in the hook body.
- (9) From the slit (1) pass the thread underneath the hook body (2), and pull it to the right diagonally, and the thread will pass through tension spring.
- (10) Leave the end of thread inserted through to the tension spring as it is.
- (11) While holding the end of upper thread by left hand, turn the balance wheel slowly once around by right hand.
- (12) Then the upper thread will hook out the lower thread simultaneously through the hole of needle plate, and leave the lower thread to other side of the needle plate.
- (13) After placing the bobbin, close the slide plate.

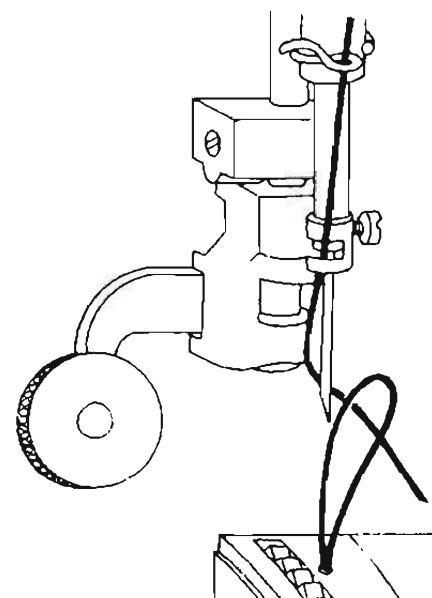
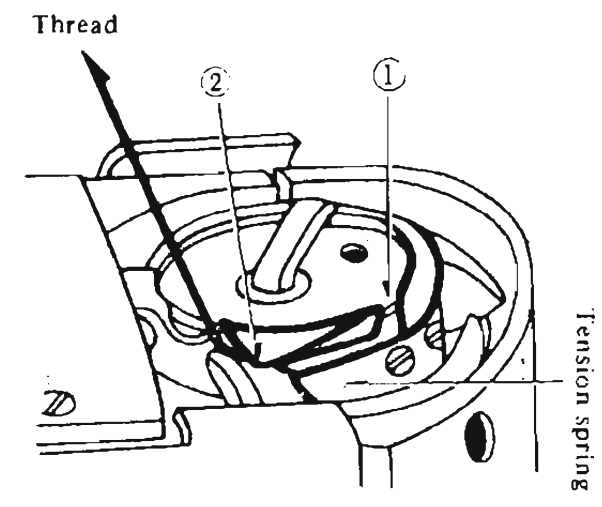
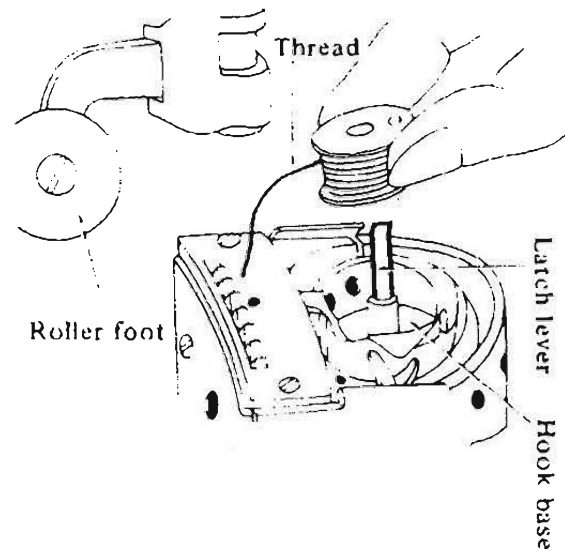

* Preparation for operation

In case of Two Needle Type

- (1) Raise the needle bar to its highest position turning the balance wheel by hand.
- (2) In the event of the roller foot is attached, move it to the left as shown in Fig.
- (3) Move the both slide plate.
- (4) Turn up the both of the latch lever as shown in Fig.
- (5) Pull out the bobbin thread for about 5 cm. and hold the bobbin.
- (6) Fit the bobbin into the both hook base.
- (7) Flap down the both latch lever as it was.
- (8) Insert the pulled thread end through slit (1) of the hook.
- (9) From the slit (1) of the hook, pass the thread through underneath of the hook body (2), pull the left thread to the left and the right thread to the right diagonally and the thread will pass through the tension spring as shown in Fig.
- (10) Leave the end of the thread inserted through the tension spring as it is.
- (11) While holding the end of 2-upper thread by left hand, turn the balance wheel slowly once around by right hand.
- (12) Then the 2-upper thread will hook out pulling the lower thread simultaneously through the hole of needle plate, and leave the lower thread to the other side of the needle plate as shown in Fig.
- (13) After placing the bobbin; close the both of the slide plate.

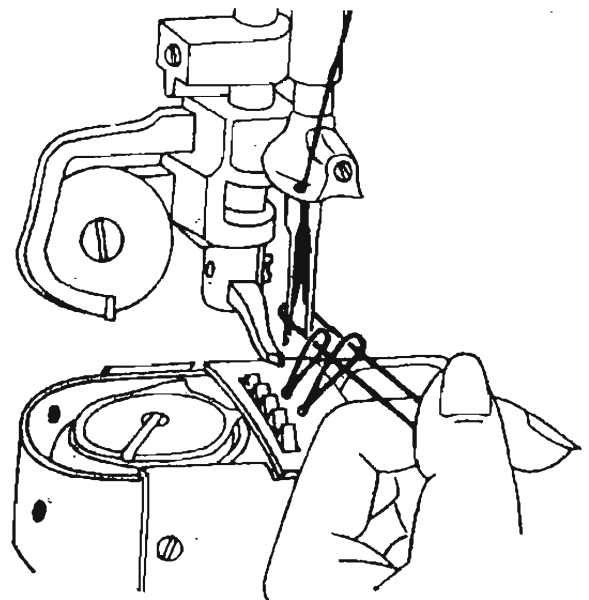
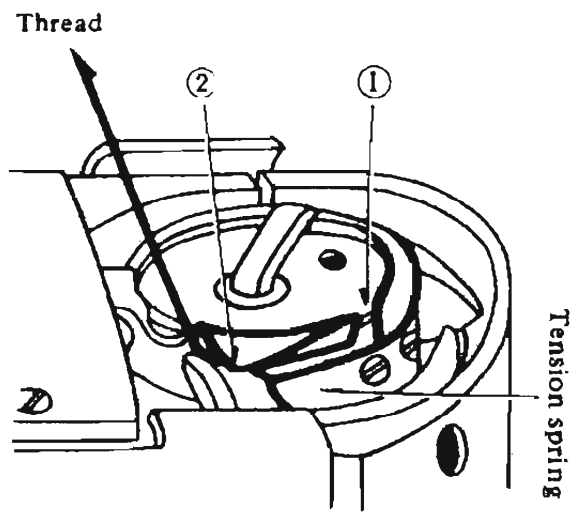
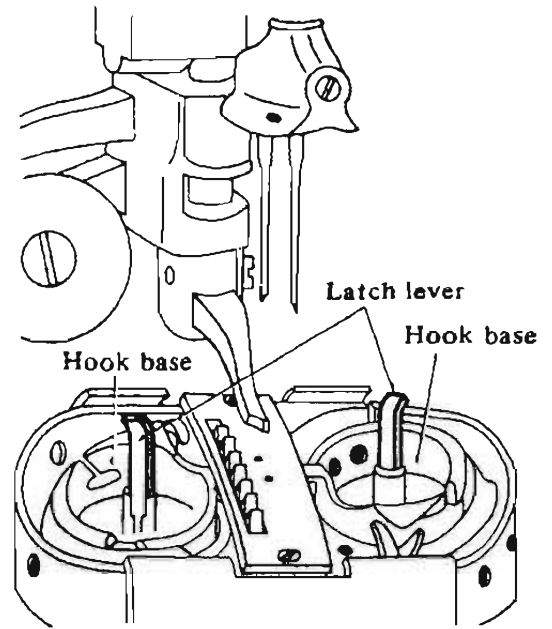

III HOW TO OPERATE

1. STARTING TO SEWING.

- (1) Raise the presser bar lifter.
- (2) Move back the roller foot toward your side as shown in Fig. by the arrow.
- (3) Place starting end of the materials for stitching under the needles.
- (4) Turn the balance wheel by hand toward your side so that the needle stitches the materials.
- (5) Lower the presser bar lifter and start to sew.

* When starting to sewing, leave the upper thread pulled out by approx. 10cm in length so that it will not pull out from needle.

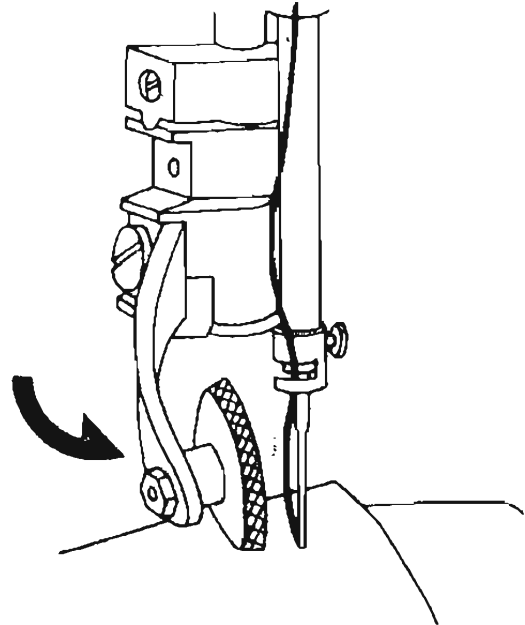

2. SEWING OVER

- (1) Stop sewing when the take up lever comes to its highest position.
- (2) Raise the presser (roller or ordinary) foot.
- (3) Pull out the stitched fabrics diagonally to the left side.
- (4) Cut both upper and lower thread.

* When cutting the thread leave out approx. 10cm length so that next starting sew is convenient for you.

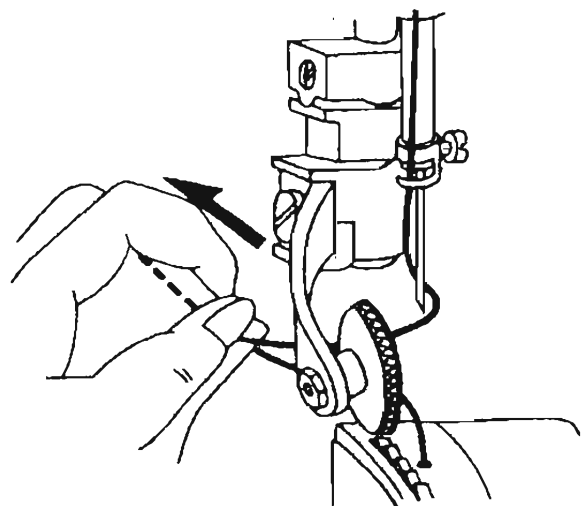

* Stitching Adjustment

IV. STITCHING ADJUSTMENT.

1. ADJUSTMENT OF STITCH LENGTH.

- ◆ Stitch length can be adjusted with the stitch regulating dial.
- ◆ Figures on the stitch regulating dial indicates the length in mm. When the dial number is set on the pin of the arm it will give your desired stitch length.

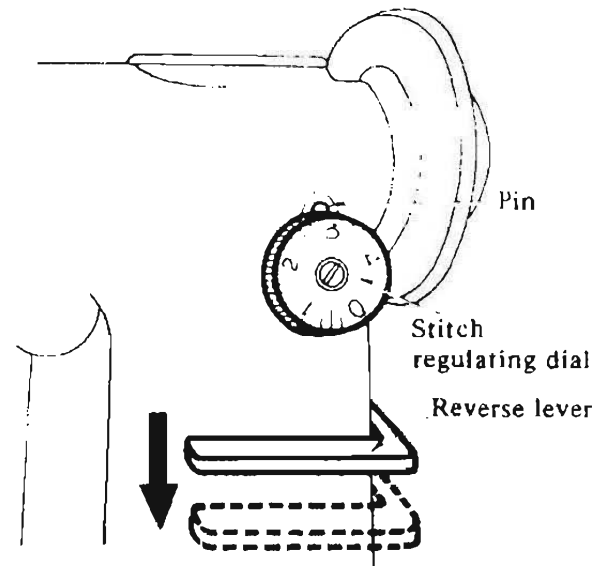

2. REVERSE STITCHING.

- ◆ Reverse stitching can be operated by means of pushing the reverse lever downward. While the lever is pressed downward, reverse stitching can be made.

3. ADJUSTMENT OF THREAD TENSION.

- ◆ The thread tension varies according to the type of materials to be sewn; or thread used, and the length of the stitches required, so adjust the tension accordingly.
- ◆ If the upper and lower thread tension are well balanced, the two thread will link together in the middle of the fabrics to provide perfect chain-like stitches (A) as shown in Fig.
- ◆ If, either the upper or lower thread tension is too tight, or too loose, it will give imperfect stitches such as (B) and (C) as shown in Fig.
- ◆ Fig. (B) shows the upper thread tension is too tight, and Fig. (C) the upper thread tension is too loose.

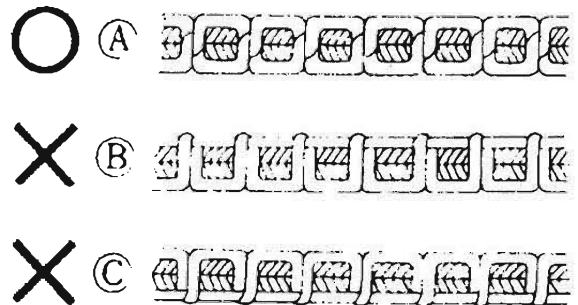

■ Tension of upper thread.

Adjustment of the upper thread tension can be achieved by changing the pressure of the tension discs of the regulator, as well as the strength and operating range of the thread take-up spring.

In case of Needle Type

1) Pressure of the thread tension discs:

- ◆ For general fabric stitching, the desired tension can be obtained just by adjusting the pressure of the tension discs.
- ◆ To strengthen, turn the thread tension nut to the right.
- ◆ To slacken, turn to the left.

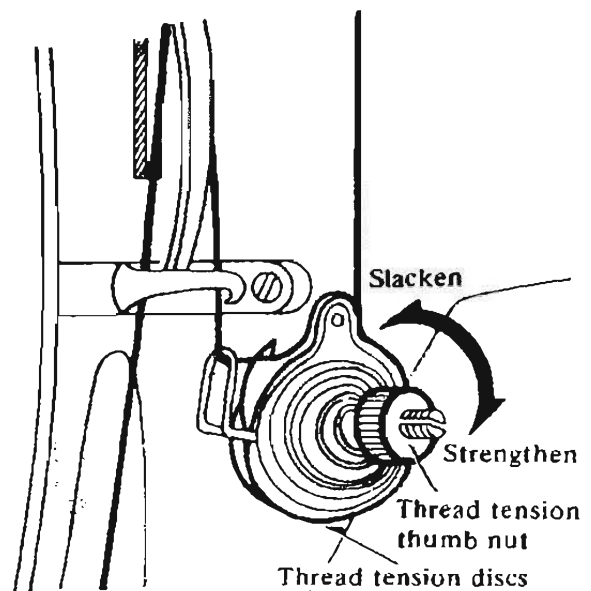

* Stitching adjustment

In case of Two Needle Type

- ◆ To strengthen the pressure of thread tension discs, turn the thread tension nut to the right.
- ◆ To slacken, turn the tension nut to the left.

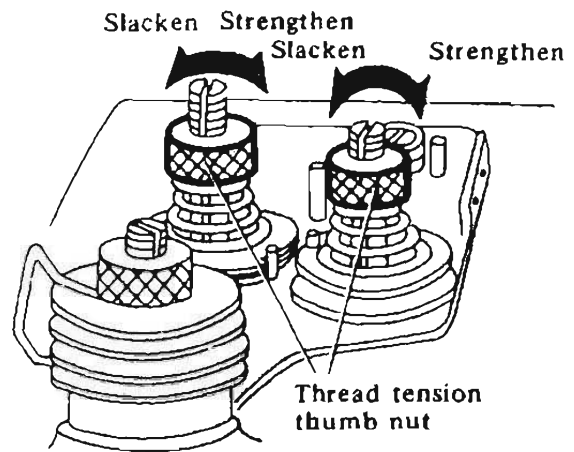

2) Strength of the thread take up spring.

- ◆ Adjust the strength of the take-up spring according to the materials to be stitched.
- ◆ Standard materials approx. 25g.
- ◆ Light materials (small stitch length)
- ◆ Heavy materials (large stitch length) strengthen the spring approx. 30g.

◆ How to adjust.

- (1) Leave the presser bar lifter down.
- (2) Remove the face plate.
- (3) Loosen the small screw inside of the face plate as shown of the upper thread tension regulator (one needle type) or of the thread tension controller (two needle type).
- (4) Fit the screw driver into the groove of the thread tension stud, or thread controller stud, and turn the stud to the left to strengthen, and to the right to slacken.
- (5) After adjusted, tighten the small screw and put the face plate back on.

(In case of One Needle Type)

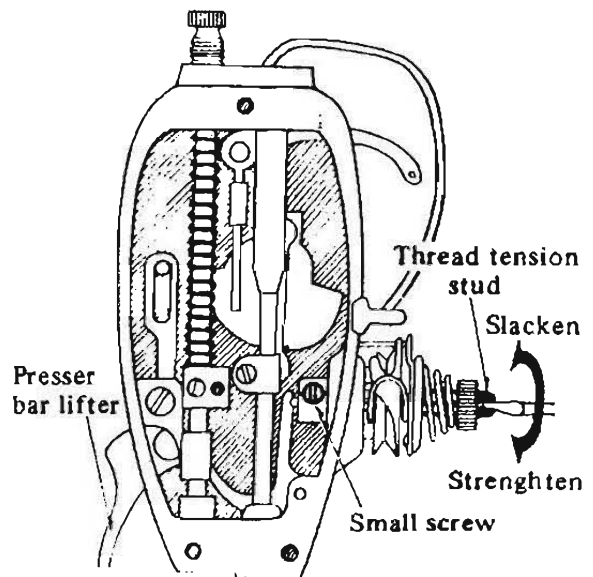

(In case of Two Needle Type)

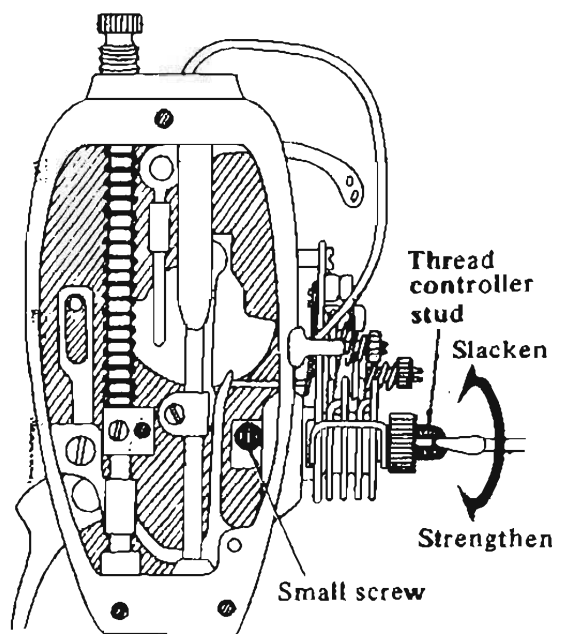

* Stitching adjustment

3) Operating range of the thread take up spring.

- ◆ In order to obtain proper working condition, it is necessary to adjust the strength of the take up spring as well as change the operating range of the take-up spring.
- ◆ The operating range can be measured when the take-up lever is at the highest position, and when the upper thread is pulled, and the tension spring moves within the width of 8mm, it is considered as standard.
- In case of standard (general fabrics) materials approx. 8mm(5/16")
- In case of light (small stitch length) materials, increase the operating range slightly approx. 8mm(5/16") or up
- In case of heavy (large stitch length) materials, decrease the operating range slightly approx. 8mm(5/16") or less

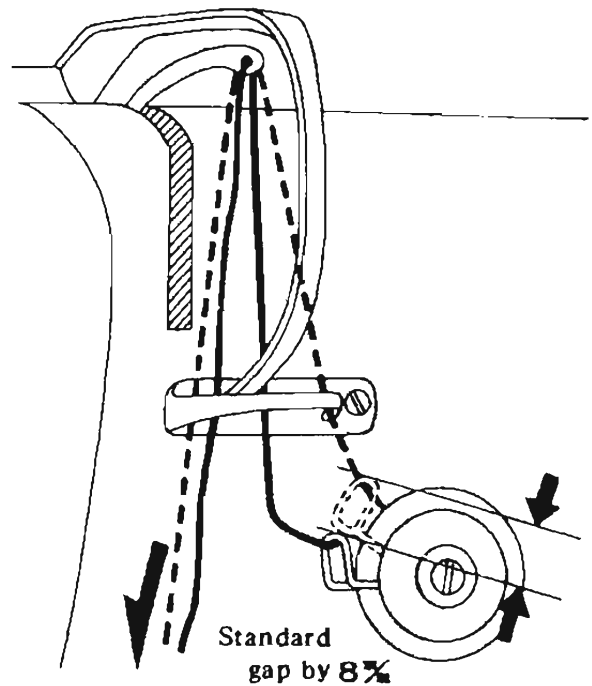

◆ How to adjustment (Needle Type)

- (1) Lower the presser bar lifter.
- (2) Loosen the thread tension regulator set screw.
- (3) Fit the screw driver into the groove of the tension regulator stud, and turn the stud to the right to small the operating range.
- (5) Turn the stud to the left to large the operating range.
- (6) After adjusted, tighten the screw.

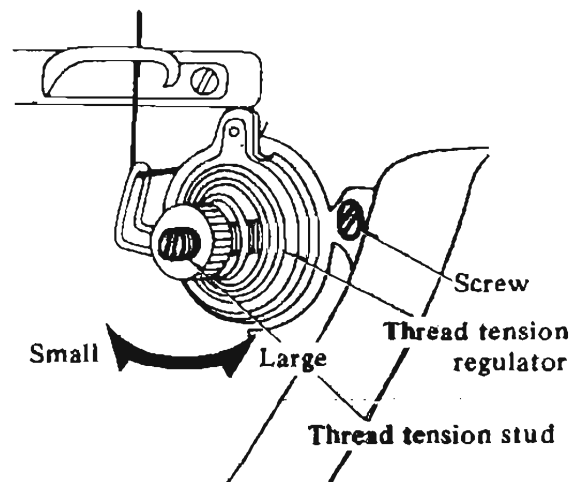

◆ How to adjust (Tow Needle Type)

- (1) Loosen the thread controller set screw.
- (2) Fit the screw driver into the groove of the thread controller stud, and turn the stud to the right to small the operating range.
- (3) Turn the stud to the left to rarge the operating range.
- (4) After adjusted, tighten the screw.

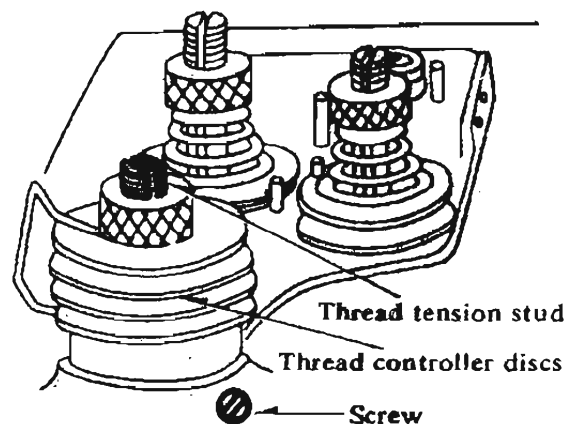

* Stitching adjustment

■ Tension of lower thread.

There is virtually no need to adjust the lower thread tension, except for special kind of fabrics or thread, when slight adjustment will be necessary.

- (1) Turn the balance wheel by hand, and stop when the thread take-up lever comes down to its lowest position.
- (2) Move the slide plate so that you find the thread tension screw of the hook base.
- (3) Fit the screw driver into the hole (A) of the hook shaft bracket as shown in Fig. Turn the tension screw to the right to strengthen the thread tension.
- (4) Turn the screw to the left to weaken the thread tension.

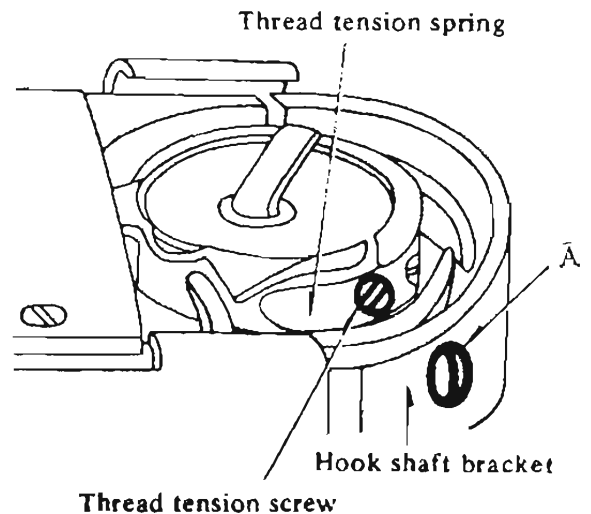

4. ADJUSTMENT OF FEED DOG HEIGHT AND PRESSURE OF PRESSER ON MATERIALS.

The feed dog height and pressure of presser on materials must be properly adjusted according to the materials to be sewn.

- ◆ In case of light materials: The material may be damaged if the feed dog is raised excessively or the pressure of presser on materials is too strong.
- ◆ In case of heavy materials: It will not make uniform stitching if the feed dog is not raised properly or the pressure of presser is too weak.

In case of light materials
.....	approx. 0.8mm in height
In case of general fabrics
.....	approx. 1.0mm. in height
In case of heavy materials
.....	approx. 1.2mm. in height

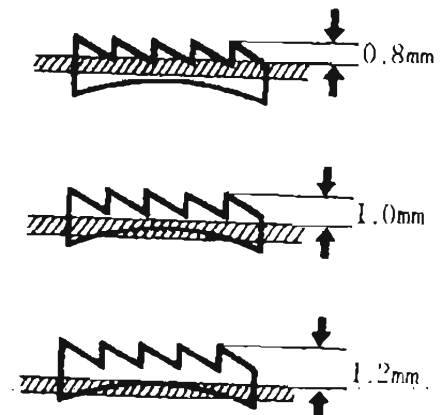

* The height of feed dog is measured when the feed dog is raised to its highest position from the surface of needle plate turning the balance wheel by hand.

1) Adjustment of feed dog height.

- (1) Lay down the machine bed toward the other side.
- (2) Remove the gear box.
- (3) Turn the balance wheel by hand and stop when the feed dog is raised to its highest position from the surface of needle plate.
- (4) Loosen the screw of feed lifting rock shaft crank.
- (5) Adjust the feed dog to the desired height moving the feed lifting rock shaft crank back and forth as per an arrow shown in Fig.
- (6) After adjusted, tighten the screw of feed lifting rock shaft.

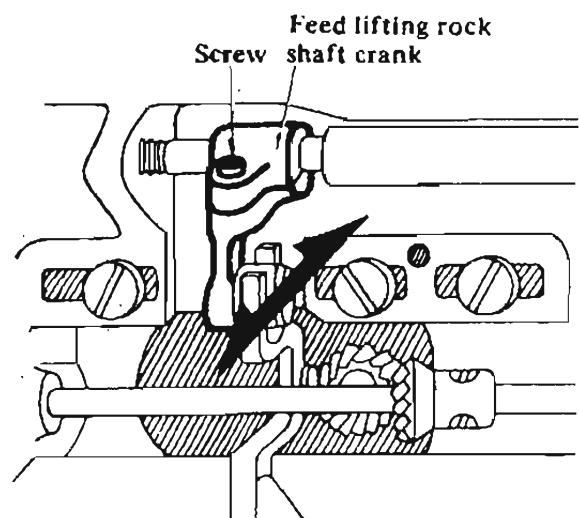

* Stitching adjustment

2) Adjustment of pressure of presser foot.

- (1) Turn the presser regulating thumb screw to the right to strengthen the pressure of presser foot.
- (2) Turn the screw to the left to loosen the pressure of presser foot.

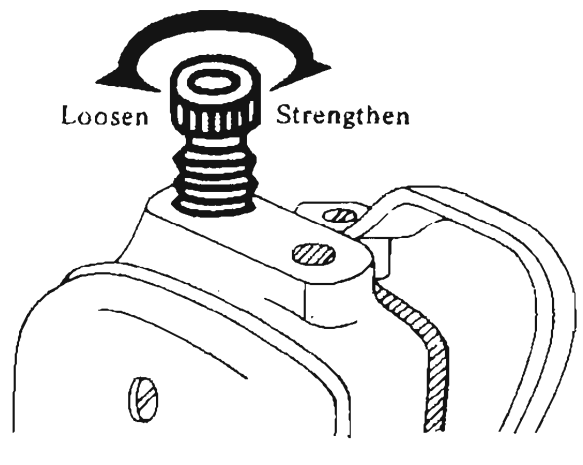

5. PROPER TIMING BETWEEN THE HOOK AND NEEDLE.

Place and adjust the hook in the condition described below in case of the thread gets entangled in the hook, or when its position is changed due to shock, or other causes, or when it is replaced with new a one.

1) How to remove the hook:

- (1) Turn the balance wheel by hand and stop when the thread take up lever comes down to its lowest position.
- (2) Remove the slide plate, then take out the bobbin.
- (3) Remove the needle plate.
- (4) Remove the hook cover plate (front) (In case of two needle type, remove the hook cover plate (upper) both the front and back.)
- (5) Remove the hook opener screw, and then remove the opener.
- (6) Loosen the hook gib screw and remove the hook gib fixed in front of the hook body as shown in Fig.
- (7) Hold the latch lever up turning it slightly so that it can be taken out.
- (8) Remove the hook body center set screw so that it can be taken out.

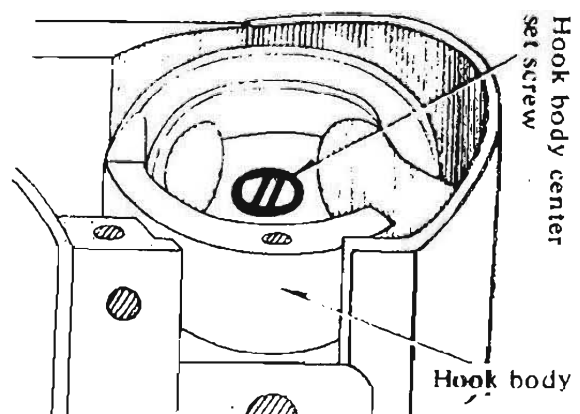
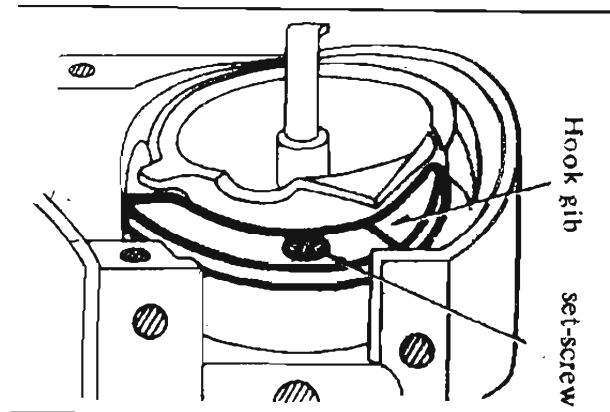
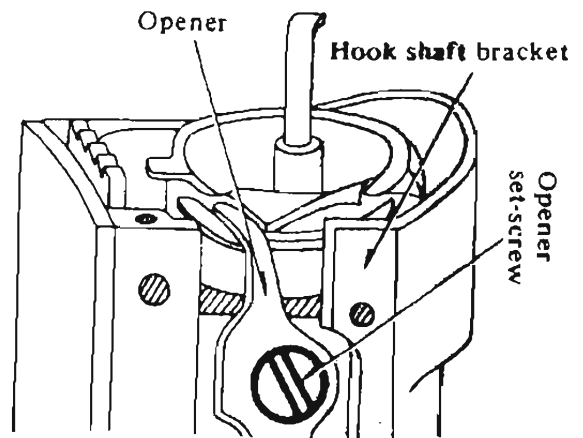

* Stitching adjustment

2) How to place the hook:

- (1) Place the hook in backward order from removing procedure.
- (2) When placing the hook body, remember to place it at the same position as it was taken out.
- (3) When inserting the hook base hold the hook base cap turning it to the left as shown in Fig., and fit the hook base brim into slot of the hook body on the inside of the other side.
- (4) When placing the needle plate, place the needle plate adjusting the hook base so that the tip of hook base fits into the hook finger of the needle plate as shown in Fig.

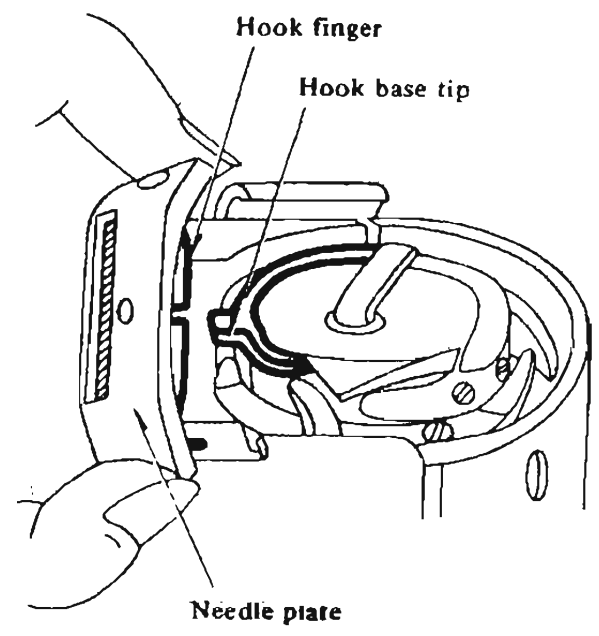
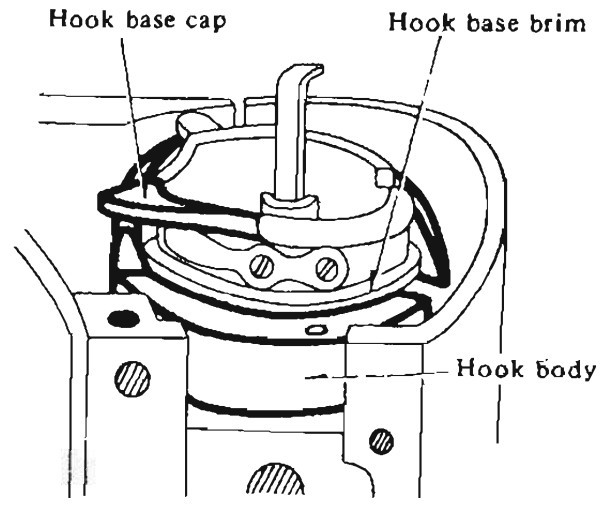

3) The position of the hook and needle:

As shown in the Fig., when the needle raised is 2.0mm from its lowest position of the needle, the hook and needle should be as follows.

- ◆ Upper part of the needle hole Lower by 1.6mm from the tip of hook.
- ◆ Tip of hook At center of needle.
- ◆ Gap between tip of hook and lateral face of needle by 0.05mm.

Adjustment of the relative position of the hook and needle can be done as follows:

- * Move the roller foot to the left, remove the needle plate for easy adjustment.

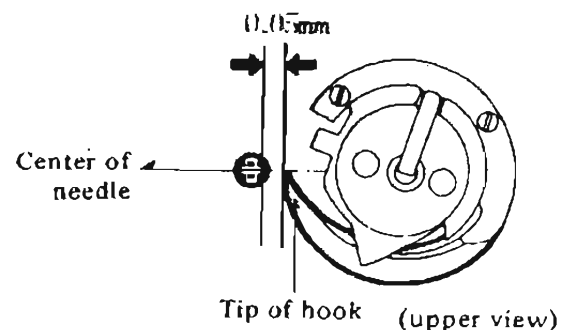
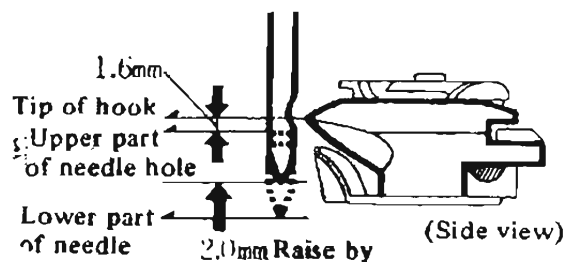

* Stitching adjustment

■ Adjustment of needle bar position.

Adjust the needle bar timing so that the gap between the tip of hook and the upper part of needle hole will be 1.6mm when the needle is raised by 2.0mm from its lowest position.

- (1) Raise the needle bar by 2.0mm from its lowest position turning the balance wheel by hand.
- (2) Loosen the needle bar connecting stud screw through a driver hole (lower) of the face plate.
- (3) Adjust moving the needle bar up and down so that the tip of hook comes at the position by 1.6mm from the upper part of needle hole.
- (4) After adjusting the needle bar position, tighten the needle bar connecting stud screw.

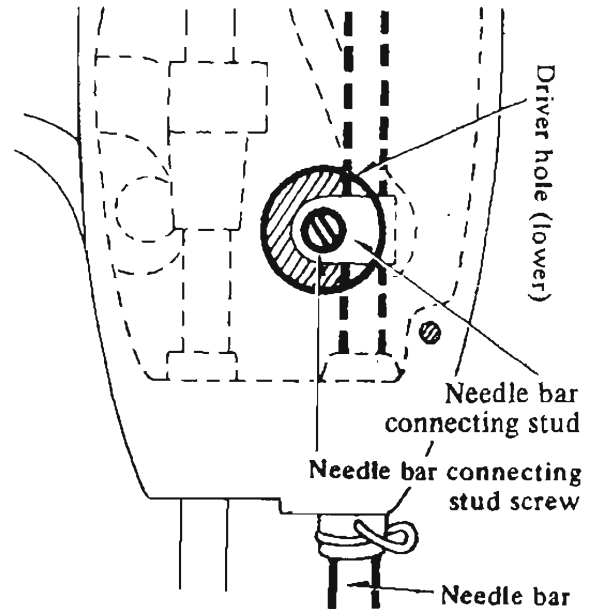

(In case of One Needle Type)

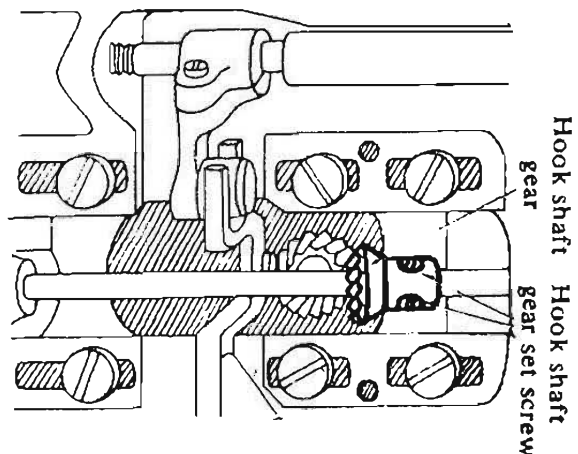

■ Adjustment of tip of hook.

- ◆ Adjust so that the tip of hook comes to the center of needle.

- (1) Remove the needle plate and slide plate.
- (2) Lay down the machine head toward the other side.
- (3) Remove the gear box.
- (4) Loosen the two set screws of the hook shaft gears.
- (5) Turn the balance wheel by hand, and stop when the needle is raised 2.0mm from its lowest position.
- (6) Turn the hook by hand enabling the tip of hook to come to the center of needle.
- (7) After adjusting, tighten the two set screws of the hook shaft gears.
- (8) Place the gear box.

(In case of Two Needle Type)

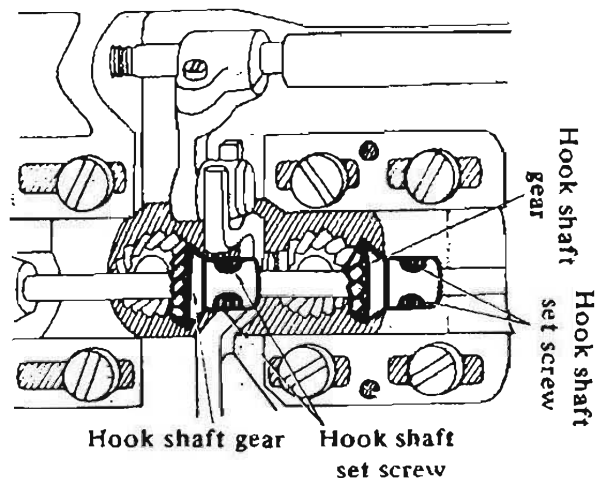

◆ Adjust that the gap between the tip of hook and lateral side of the needle to come to 0.05mm. In case of 1-needle, there is virtually no need to adjust it. However, in case of 2-needle, it is necessary to adjust it when changing the needle gauge sizes.

- (1) Loosen the screws of the hook post cover plate (front and back).
- (2) Lay down the machine head toward the other side.
- (3) Remove the gear box.
- (4) Loosen the hook shaft gear set screws.
- (5) Loosen the set screws of hook shaft bracket.
- (6) Turn the balance wheel by hand, and stop when the needle is raised by 2.0mm from its lowest position.
- (7) Turn the hook by hand and bring the tip of hook to the center of needle.
- (8) Move the hook shaft bracket of the right and left, so that the gap between the tip of hook and lateral side of needle is 0.05mm.
- (9) After adjusting, tighten the set screws of hook shaft gear and bracket.
- (10) Place the gear box.

(In case of Two Needle Type)

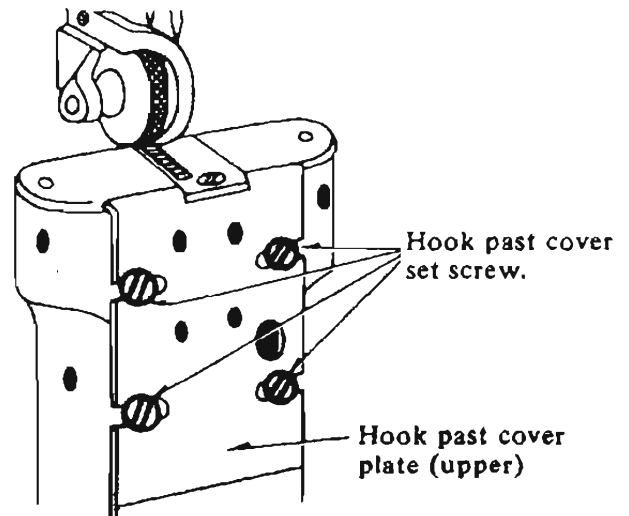

(In case of Two Needle Type)

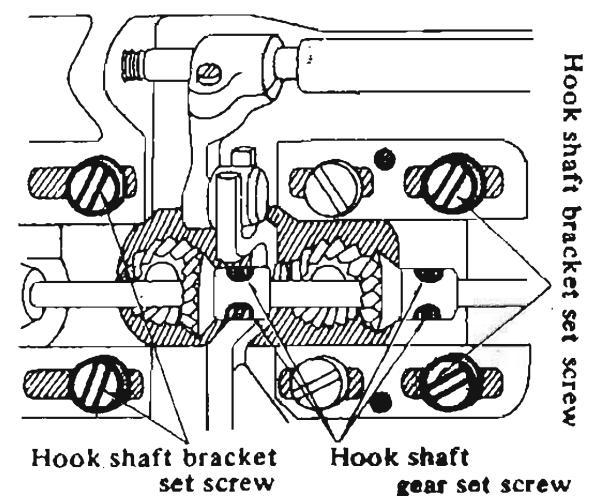

Approx.
0.2m/m

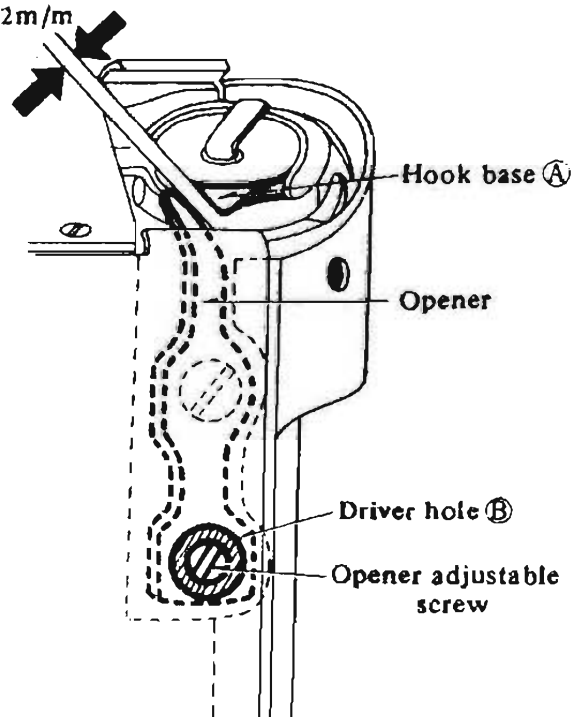

6. PROPER TIMING BETWEEN THE HOOK AND OPENER.

- (1) Remove the slide plate.
- (2) Turn the balance wheel by hand, and stop at the position where the opener and the needle plate are furthest apart.
- (3) Check whether the gap between the part of hook base (A) and the opener is approx. 0.2mm as shown in Fig. (there is a slight difference according to the thread to be used)
- (4) In case the gap is too wide or narrow, adjust it fitting the screw driver into a driver hole (B) of the hook shaft bracket, then loosen the opener adjustable screw and moving the opener to the right or left.
- (5) After adjustment, tighten the opener adjustable screw.

* Stitching adjustment

7. PROPER TIMING BETWEEN THE FEED DOG AND NEEDLE.

The proper timing of the feed dog and needle will be when the material is fed through and the needle tip reach to the needle plate surface, just at the moment the feed dog begins to sink downward through the needle plate surface as shown in Fig.

This adjustment is based on the feed dog height is at 1.0mm.

- (1) Loosen the arm side cover thumb screw.
- (2) Move the side cover to the right, and open to upper side as shown in Fig.
- (3) Loosen the set 2-screws of the feed lifting cam.
- (4) While holding the feed lifting cam by hand, turn the balance wheel toward your side so that feeding device will be faster.
- (5) In order to slow the feeding device, turn the balance wheel toward the other side.
- (6) After adjustment, tighten the set screws of the feed lifting cam.

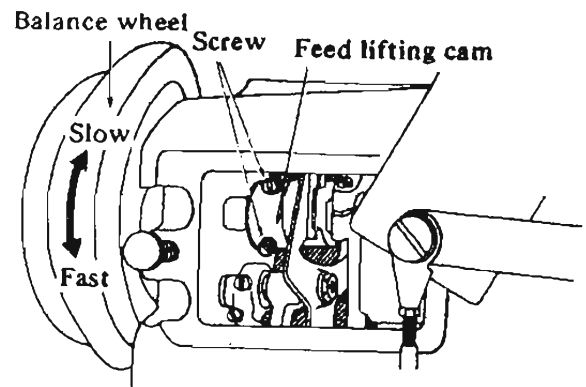
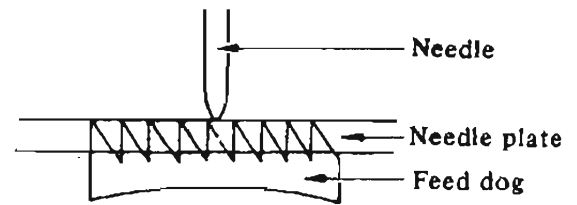

V. CLEANING AND LUBRICATION.

1. Cleaning.

The teeth of feed dog, hook, upper thread tension regulator discs, and thread controller discs are often covered by dust and lint causing improper operation and uneven stitching. Therefore, clean as often as necessary.







2. Lubrication.

Lubrication is one of the most important phases of the machine maintenance. With improper lubrication, excess abrasion of machine parts will cause to shorten the life of the machine. Therefore, lubricate in the order as follows:

1) The number of times for lubrication.

- (1) Usual working at 2 - 3 times per week.
- (2) Continuous working, every day . . . once each day

2) Volume of lubrication:

- Places   marked . . . approx. 5cc or more
 place   marked . . . approx. 5 - 6 drops
 place   marked . . . approx. 1 - 2 drops

3) Places where to lubricate.

Lubricate the places where arrow is shown in Fig. (inside of face plate, arm bed)

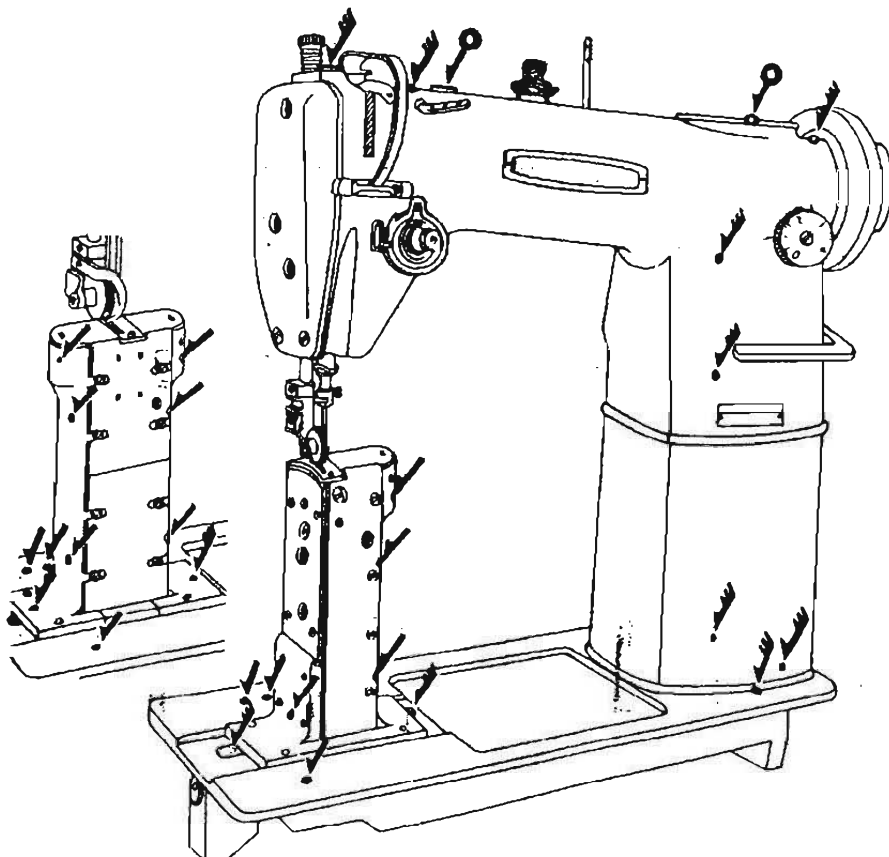

* Cleaning and lubrication

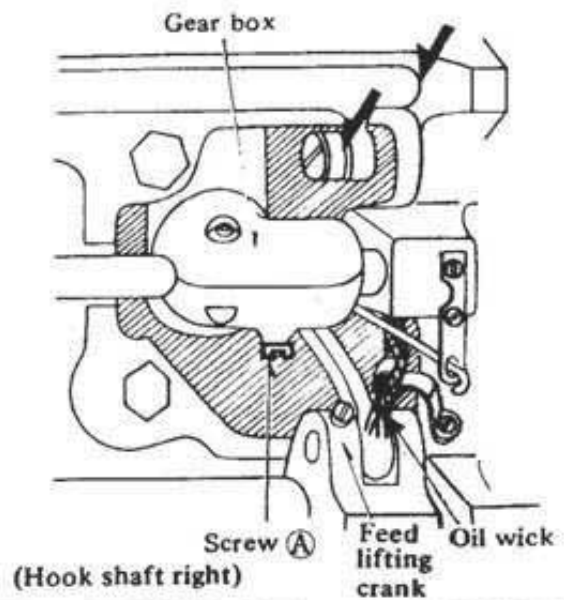
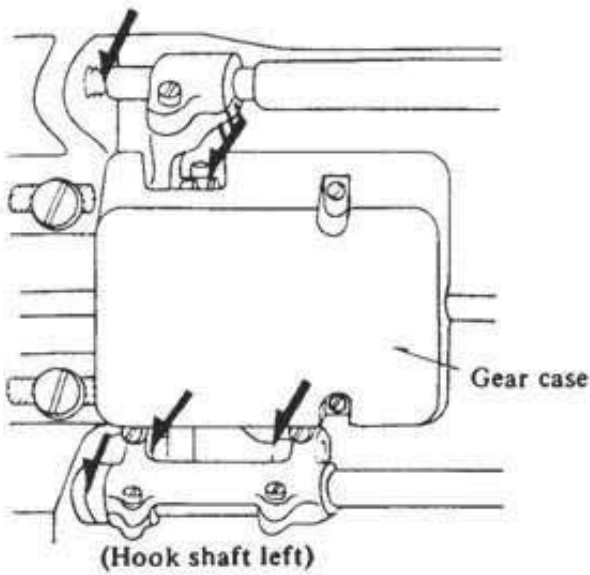

- * Since the oil wick connected with the feed lifting crank for the right side of hook shaft is worked to flow oils, penetrate oil fully before working (if the oil wick is not penetrated with oil, it has no effect to flow oil).

GREASE.

- 1) Remove the oil hole screws (A) & (B), of the gear box fixed to arm and hook shaft, then grease into the holes periodically.
- 2) Remove the gear case of the left side of hook shaft, then also grease into the gears sufficiently.

