

# ***PARTS LIST***

## **LZ-2290C PARTS LIST**

下記 URL (PARTS Website/PC サイト) より、便利な検索機能のついた Web Parts Book をご利用頂けます。  
ご利用には会員登録が必要です。(無料)

<https://juki.aftama.com/JUKI/JA>

You can use a Web Parts Book with a convenient search function from the URLs (PARTS Website/PC-site)  
below. To use the PARTS Website, free membership registration is required.

<https://juki.aftama.com/JUKI/EN>



## HOW TO MAKE USE OF THIS PARTS LIST

### 1.Explanation of codes

1)"\*" mark.....means this part is changed from the previous parts book.

As to the details of the change, refer to "List for information of change".

2)"#01".....refer to "Note" explanation at bottom of page.

### 2.Codes on the "Qty" column

• Each numeral indicates the number of parts required.

• "0.1" and "2.5" indicate the length (in meters) of the respective parts.

3.Parentheses mean that the corresponding part is a subpart that constructs an assembly part.

4.Dotted lines on the Figures indicate assembly parts.

5.As to the parts with marks of "☆" (consumable parts) and "◎" (optional parts) on the respective parts,

it is recommended to prepare spares.

## パーツリストご利用に際して

### 1. "注記" 欄の記号説明

1) "\*" 印 ..... 前回のパーツブックに比較して今回変更された部品を意味します。

変更内容は "変更情報リスト" を参照してください。

2) "#01" ..... ページ下の "注記" の説明を参照してください。

2. 数量欄の数字は、個数を表し、0.1、2.5 等の数値は、長さ（単位メートル）を表します。

3. 数量欄の（ ）は、組部品を構成している子部品であることを意味します。

4. イラストページの-----枠は、組構成であることを意味します。

5. リストページの "☆"（消耗部品）、"◎"（オプション部品）の印がついた部品は、

予備を準備しておくことをお奨めします。

# CONTENTS

## 目次

1. FRAME & MISCELLANEOUS COVER COMPONENTS (1) .....	1
頭部・外装関係（1）	
2. FRAME & MISCELLANEOUS COVER COMPONENTS (2) .....	3
頭部・外装関係（2）	
3. BOBBIN WINDER COMPONENTS .....	5
糸巻装置関係	
4. MAIN SHAFT & THREAD TAKE-UP & NEEDLE BAR COMPONENTS .....	7
上軸・天秤・針棒関係	
5. NEEDLE VIBRATOR COMPONENTS .....	9
針振り関係	
6. HAND LIFTER COMPONENTS .....	11
押え上げ関係	
7. HAND LIFTER COMPONENTS (AK156) .....	13
押え上げ関係（AK156）	
8. FEED MECHANISM COMPONENTS .....	15
送り関係	
9. HOOK DRIVING SHAFT COMPONENTS (1) .....	17
下軸関係（1）	
10. HOOK DRIVING SHAFT COMPONENTS (2) .....	19
下軸関係（2）	
11. THREAD TENSION COMPONENTS (TYPE FULL DIGITAL).....	21
糸調子関係（フルデジタル仕様）	
12. THREAD TENSION COMPONENTS (TYPE DIGITAL) .....	23
糸調子関係（デジタル仕様）	
13. THREAD FEEDER COMPONENTS.....	25
糸繰り出し関係	
14. LUBRICATION COMPONENTS .....	27
給油関係	
15. THREAD TRIMMER MECHANISM COMPONENTS .....	29
糸切り関係	
16. WIPER COMPONENTS .....	31
ワイパー関係	
17. OPERATION PANEL COMPONENTS .....	33
操作パネル関係	
18. UNDER COVER COMPONENTS .....	35
アンダーカバー関係	
19. THREAD STAND COMPONENTS .....	37
糸立装置関係	
20. ACCESSORIE PARTS COMPONENTS .....	39
付属品関係	

21. SPECIAL ORDER PARTS.....	41
特別注文部品	
22. LIST FOR INFORMATION OF CHANGE.....	43
変更情報リスト	
NUMERICAL INDEX OF PARTS .....	44
索引	

# 1. FRAME & MISCELLANEOUS COVER COMPONENTS (1)

頭部・外装関係 (1)

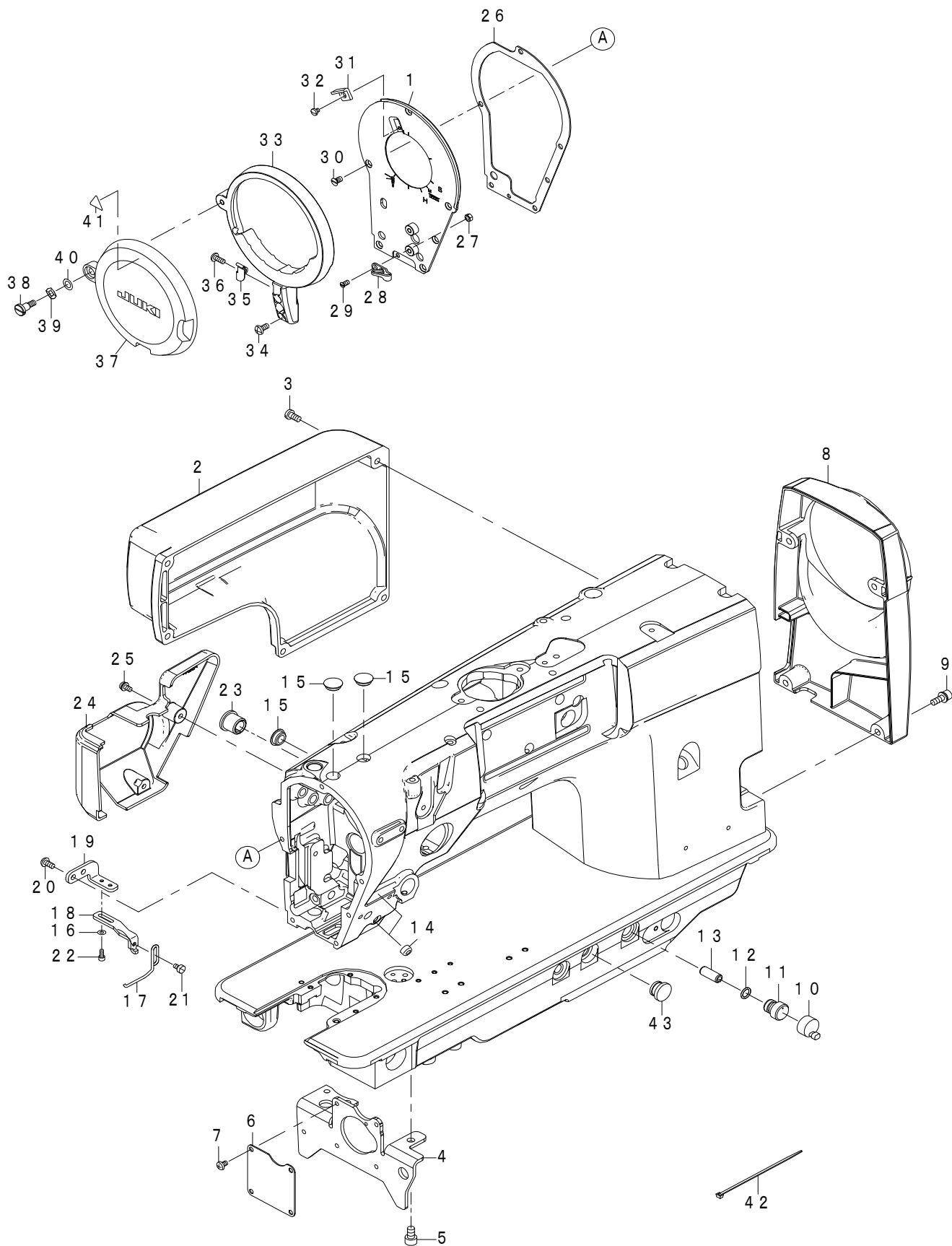

REF.NO	NOTE	PART NO	DESCRIPTION	品名	Qty
1		402-19949	FACE_PLATE_ASM	面板(組)	1
2		402-16994	MOTOR_COVER	モータカバー	1
3		SM-4051055-SP	SCREW	なべねじ	5
4		402-09318	VERTICAL_MOTOR_BASE	上下モータ土台	1
5		SM-6061002-TP	SCREW M6 L=10	六角穴ボルト M6 L=10	2
6	#02	402-09311	OIL_GUARD_PLATE_S	油防板S	1
7	#02	SM-4040655-SP	SCREW M4 L=6	なべ小ねじ M4 L=6	4
8		401-72366	PULLEY_COVER	プーリーカバー	1
9		SL-6051492-TN	BOLT	座金付き六角穴ボルト	4
10		236-01305	AIR-DISCHARGING CAP	エアー抜きキャップ	1
11		236-29900	AIR-DISCHARGING	エアー抜き	1
12		RO-0801502-00	RUBBER RING	Oリング	1
13		PS-0800202-KH	SPRING PIN 8X20	スプリングピン 8X20	1
14		GPR-01015000	DRIVING STOPPER RUBBER	差動ストッパゴム	2
15		TA-1250406-R0	RUBBER PLUG D=12.5 L=4	止め栓 D=12.5 L=4	3
16	#01	WP-0330500-0E	WASHER 3.3X6X0.5	平座金 3.3X6X0.5	2
17	#01	225-29002	SUPPORT BALANCE	補助天秤	1
18	#01	225-29101	SUPPORT BALANCE BASE	補助天秤台	1
19	#01	225-29200	MOUNTING BASE	補助天秤取付台	1
20	#01	SS-4120915-SP	SCREW 3/16-28 L=9	なべねじ 3/16-28 L=9	2
21	#01	SS-6090540-SP	SCREW 9/64-40 L=5.0	平ねじ 9/64-40 L=5	1
22	#01	SS-6580752-TP	SCREW 1/8-40 L=7	六角穴ボルト 1/8-40 L=7	2
23		401-74322	CORD_CLAMP_BUSH	コード押えブッシュ	1
24		402-09335	AT_COVER	A Tカバー	1
25		SL-4040881-SC	SCREW M4 L=8	座金付きなべ小ねじ M4 L=8	2
26		401-25433	GASKET	ガスケット	1
27		NS-6090310-SP	NUT 9/64-40	六角ナット 9/64-40	1
28		263-05409	BALANCE THREAD GUIDE B	天秤糸案内B	1
29		SS-2090710-TP	SCREW 9/64-40 L=7.2	丸皿ねじ 9/64-40 L=7.2	1
30		SS-1110840-SP	SCREW 11/64-40 L=8	皿ねじ 11/64-40 L=8	6
31		100-01709	TAKE-UP THREAD CUTTER	天秤メス	1
32		SS-7080410-SP	SCREW 1/8-44 L=3.8	丸平ねじ 1/8-44 L=3.8	1
33		402-09349	BALANCE_COVER_BASE	天秤カバー台	1
34		SS-4110915-SP	SCREW 11/64-40 L=9	なべねじ 11/64-40 L=9	2
35		263-05300	BALANCE COVER STOPPER SPRING	天秤カバーストップばね	1
36		SS-4120615-SP	SCREW 3/16-28 L=6	なべねじ 3/16-28 L=6	1
37		402-09348	BALANCE_COVER	天秤カバー	1
38		SD-0640751-SP	HINGE SCREW D=6.35 H=7.5	段ねじ D=6.35 H=7.5	1
39		WZ-0641510-KP	WAVED WASHER 6.4X11X0.3	波形座金 6.4X11X0.3	1
40		WP-0651056-SD	WASHER 6.5X11X1	平座金 6.5X11X1	1
41		CM-3002000-01	ATTENTION SEAL	指げが注意シール(16)	1
42		EA-9500B01-00	CABLE BAND	束線バンド	4
43		TA-1250705-R0	RUBBER PLUG	止め栓	1
		NOTE(注記)	#01 ....VARIOUS NOS.FOR DESTINATIONS	仕向地により異なる	
			#02....FOR LZ-2290CS	LZ-2290CS用	

## 2. FRAME & MISCELLANEOUS COVER COMPONENTS (2)

頭部・外装関係 (2)

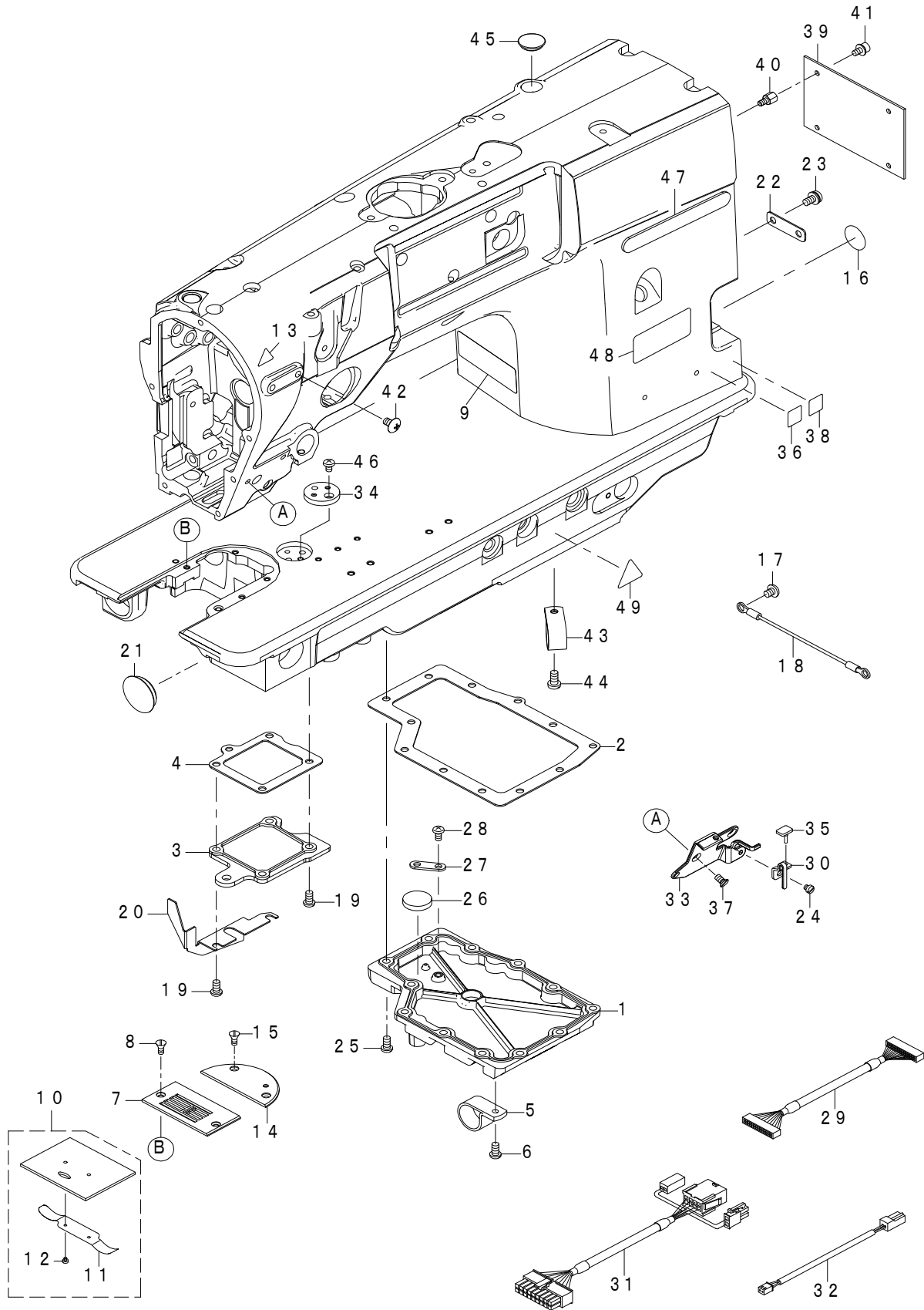



REF.NO	NOTE	PART NO	DESCRIPTION	品名	Qty
1		400-11345	GEAR BOX (LARGE) COVER	ギヤボックス蓋 (大)	1
2		235-26601	GEAR BOX (LARGE) PACKING	ギヤボックスパッキン (大)	1
3		400-28463	GEAR BOX (SMALL) COVER	ギヤボックス蓋 (小)	1
4		235-26809	GEAR BOX (SMALL) PACKING	ギヤボックスパッキン (小)	1
5		HX-0015000-0L	CABLE CLIP	ケーブルクリップ	1
6		SS-4120915-SP	SCREW 3/16-28 L=9	なべねじ 3/16-28 L=9	1
7		225-82407	NEEDLE PLATE	針板	1
8		SS-2090810-SP	SCREW 9/64-40 L=7.5	丸皿ねじ 9/40 L=7.5	2
9		402-13295	SAFETY_LABEL_S_N	安全ラベルSN	1
10	#03	263-14757	BED SLIDE ASM.	滑り板 (組)	1
11		110-01609	BED SLIDE SPRING	滑り板ばね	(1)
12		SS-6060210-SP	SCREW 3/32-56 L=1.9	平ねじ 3/32-56 L=1.9	(2)
13		CM-3002000-01	ATTENTION SEAL	指げが注意シール (16)	1
14		263-00103	SEMILUNAR PLATE	半月板	1
15		SS-2090810-SP	SCREW 9/64-40 L=7.5	丸皿ねじ 9/40 L=7.5	2
16		229-01805	GROUND MARK	グラウンドマーク	1
17		SM-4050655-SP	SCREW M5 L=6	なべ小ねじ M5 L=6	1
18		401-89389	GROUND WIRE ASM	アース線組	1
19		SS-4120915-SP	SCREW 3/16-28 L=9	なべねじ 3/16-28 L=9	4
20		402-09352	OIL_GUARD	釜オイル切り板	1
21		400-28294	FEED_ADJUSTING_CAP	送り調節体キャップ	1
22		260-25106	SPACER PLATE	布押え下板スペーサ	1
23		SL-4051091-SC	SCREW M5X0.8 L=10	なべ小ねじセムス M5X0.8 L=10	1
24		SS-7090410-SP	SCREW 9/64-40 L=3.5	丸平ねじ 9/64-40 L=3.5	1
25		SS-4121215-SP	SCREW 3/16-28 L=12	なべねじ 3/16-28 L=12	12
26		B8228-125-000	OIL RESERVOIR MAGNET	磁石	1
27		400-24644	MAGNET WASHER	マグネット押え座金	1
28		ST-4040821-SS	TAPPING SCREW	タッピングねじ	1
29	#02	402-08473	INT CABLE EX ASSY	INTケーブルEX組	1
30		401-25438	THREAD GUIDE	糸案内	1
31		402-08472	SOL-INT CABLE ASSY	SOL-INTケーブル組	1
32		402-08474	FAN RELAY CABLE ASSY	ファン中継ケーブル組	1
33		402-19875	THREAD GUIDE C	天秤糸案内C	1
34		400-35589	RULER PLATE	定規板	1
35		401-25710	RUBBER STOPPER	ストッパーゴム	1
36	#01	401-50131	EAC_MARK_LABEL_S	EACマークラベルS	1
37		SS-1110840-SP	SCREW 11/64-40 L=8	皿ねじ 11/64-40 L=8	2
38	#01	CM-6001001-01	WEEE MARK LABEL S	WEEE マーク ラベル S	1
39		402-08490	INT PCB ASSY	INT基板組	1
40		401-88608	SPACER	スペーサ	4
41		SL-4040881-SC	SCREW M4 L=8	座金付きなべ小ねじ M4 L=8	4
42		SM-0050801-SC	SCREW	トラスねじ M5 L=8	2
43		HX-0015000-0L	CABLE CLIP	ケーブルクリップ	1
44		SM-4051055-SP	SCREW	なべねじ	1
45		TA-1600406-R0	PLUG	止め栓 D=16 L=3.5	1
46		SM-4040655-SP	SCREW M4 L=6	なべ小ねじ M4 L=6	1
47		401-72375	EMBLEM_JUKI_SMART_SOLUTIONS	エンブレム_JUKIスマートソリューション	1
48	#01	400-94561	SEWING MACHINE LABEL (EU)	単体頭部銘板 (EU)	1
49		CM-3002000-03	ATTENTION LABEL	指げが注意シール (31.5)	1
		NOTE(注記)	#01....VARIOUS NOS.FOR DESTINATIONS	仕向地により異なる	
			#02....FOR LZ-2290CF	LZ-2290CF用	
			#03....FOR LZ-2290CS-0B	LZ-2290CS-0B用	

### 3. BOBBIN WINDER COMPONENTS

糸巻装置関係

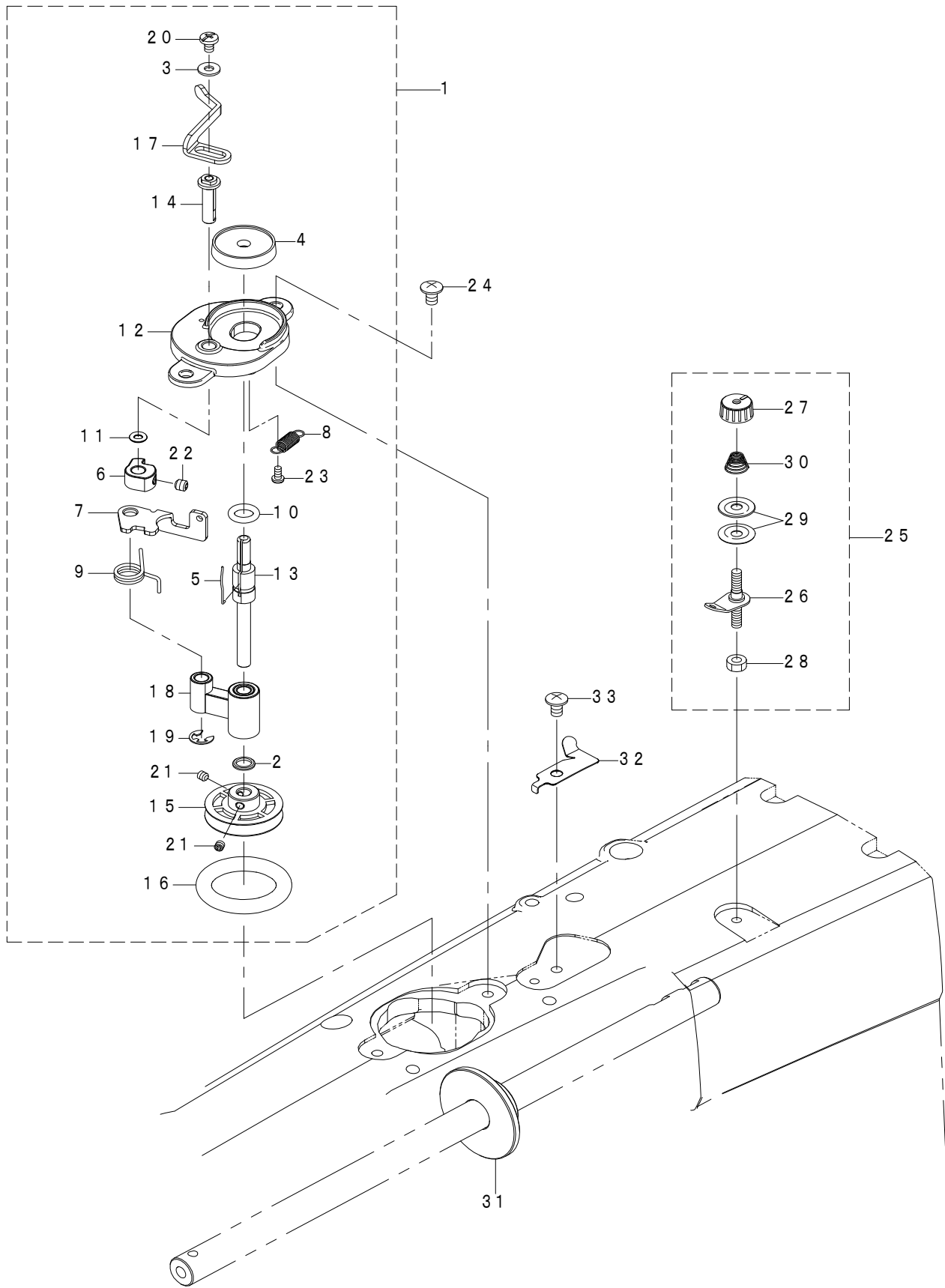

REF.NO	NOTE	PART NO	DESCRIPTION	品名	Qty
1		401-91107	BOBBIN_WINDER_UNIT_N	糸巻装置(組)N	1
2		228-91204	BEARING SUPPORT	ベアリング押え	(1)
3		401-66870	WASHER	平座金	(1)
4		401-66872	BOBBIN_SUPPORT	ボビン座	(1)
5		401-66881	BOBBIN_FIXED_SPRING	ボビン止めばね	(1)
6		401-66885	BOBBIN_PRESSER_CAM	糸巻きカム	(1)
7		401-66886	BOBBIN_WINDER_LEVER	糸巻き調節板	(1)
8		401-66887	BOBBIN_WINDER_LEVER_SPRING	糸巻き調節板戻しばね	(1)
9		401-66888	SPRING	糸巻き振りばね	(1)
10		401-66893	STOPPER_RUBBER	Oリング	(1)
11		401-66894	O_RING	Oリング	(1)
12		401-91108	BTW_BASE_N	糸巻き取付台N	(1)
13	☆	401-91109	BOBBIN_WINDER_SHAFT_N	糸巻き軸N	(1)
14		401-91111	BOBBIN_WINDER_ARM_SHAFT_N	糸巻きレバー軸N	(1)
15		401-91113	BOBBIN_WINDER_WHEEL_N	糸巻き車N	(1)
16		401-91114	BTW_WHEEL_RUBBER_N	糸巻摩擦車N	(1)
17		401-91115	BOBBIN_PRESSER_N	糸巻きレバーN	(1)
18		401-91116	BOBBIN_WINDER_SUPPORT_N_ASM	糸巻き腕組	(1)
19		RE-0500000-K0	E-RING	E形止め輪 5	(1)
20		SM-5040655-SN	SCREW	バインドねじ	(1)
21		SM-8040412-TP	SET SCREW M4 L=4	止めねじ M4 L=4	(2)
22		SM-8050502-TP	SCREW M5 L=5	止めねじ M5 L=5	(1)
23		ST-4030651-SN	SCREW M3X6	タッピンねじ	(1)
24		SM-0050801-SC	SCREW	トラスねじ M5 L=8	2
25		225-29481	BOBBIN THREAD TENSION ASM.	糸巻き糸調子(組)	1
26		225-29473	BOBBIN THREAD TENSION ROD ASM.	糸巻き糸調子棒(結合)	(1)
27		110-72402	THREAD TENSION NUT	第一糸調子ナット	(1)
28		NS-6110310-SP	HEXAGONAL NUT 11/64-40	六角ナット 11/64-40	(1)
29		B3214-047-000	BOBBIN WINDER TENSION DISC	糸調子皿	(2)
30		110-93606	THREAD TENSION SPRING	第一糸調子ばね	(1)
31		401-36292	BTW_DRIVING_WHEEL_ASM	糸巻駆動車(組)	1
32		400-37008	THREAD_CUTTER	糸切り保持板	1
33		SM-0050801-SC	SCREW M5 L=8	トラスねじ M5 L=8	1

#### 4. MAIN SHAFT & THREAD TAKE-UP & NEEDLE BAR COMPONENTS

上軸・天秤・針棒關係

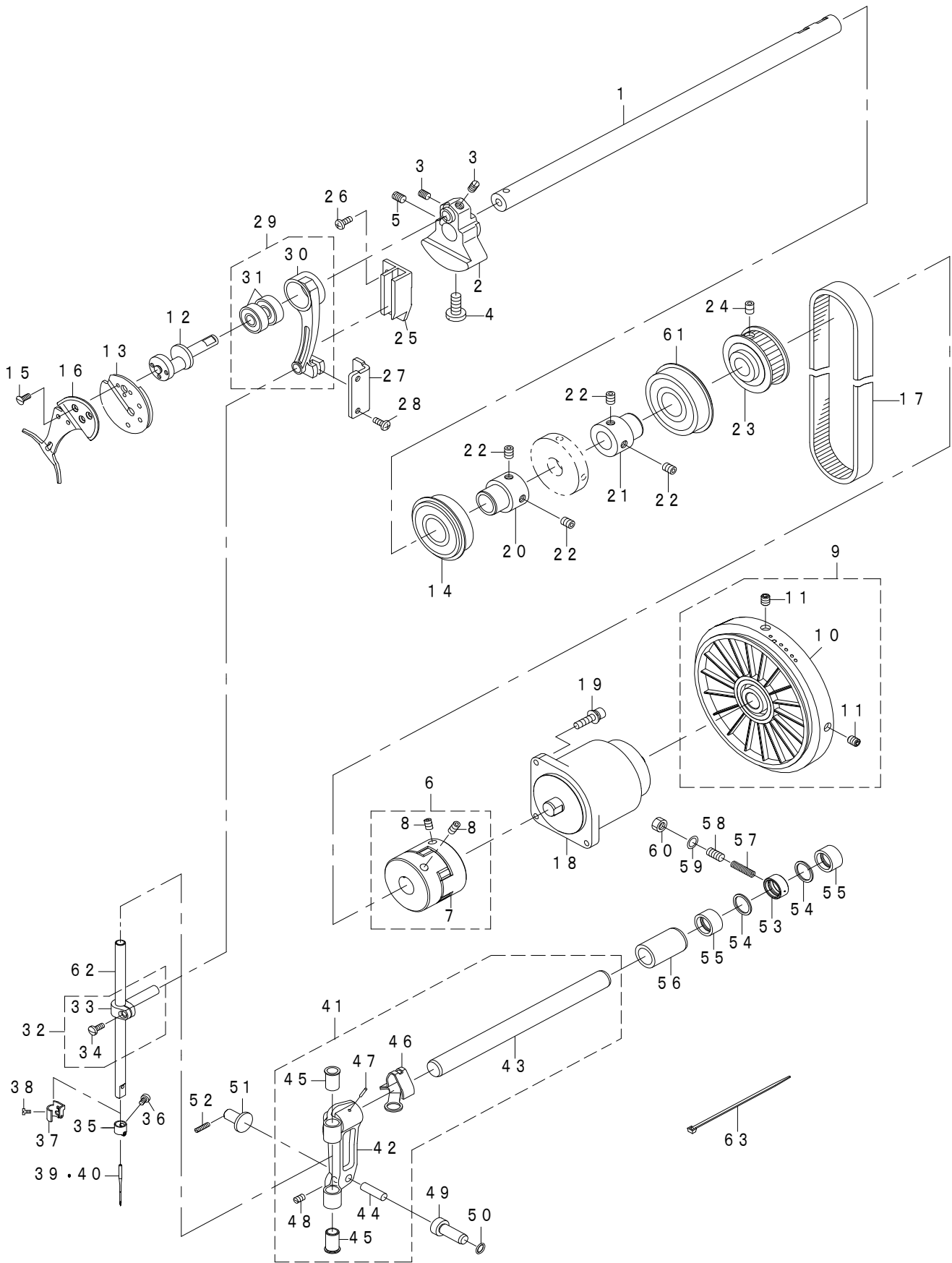

REF.NO	NOTE	PART NO	DESCRIPTION	品名	Qty
1		235-27906	UPPER SHAFT	上軸	1
2		400-10324	COUNTER WEIGHT	釣合錘	1
3		SS-8660610-TP	SCREW 1/4-40 L=6	止めねじ 1/4-40 L=6	2
4		SS-7681650-TP	SCREW 9/32-28 L=16	丸平ねじ 9/32-28 L=16	1
5		SS-8680730-SP	SCREW 9/32-28 L=7	止めねじ 9/32-28 L=7	1
6		401-72398	COUPLING_ASM.	カップリング組	1
7		401-72393	COUPLING	カップリング	(1)
8		SM-80608A2-TP	SCREW M6 L=8	六角穴付き止めねじ M6 L=8	(4)
9		401-72418	HAND_WHEEL_ASM.	はずみ車(組)	1
10		401-72377	HAND_WHEEL	はずみ車	(1)
11		SM-80608A2-TP	SCREW M6 L=8	六角穴付き止めねじ M6 L=8	(2)
12		235-28102	NEEDLE ROD CRANK	針棒クランク	1
13		100-08753	TAKE-UP COUNTERWEIGHT ASM.	天秤釣合重り(組)	1
14		SB-1200013-C0	BEARING	ころがり軸受	1
15		SS-1090930-SP	SCREW 9/64-40 L=8.6	皿ねじ 9/64-40 L=8.6	3
16		225-06208	BALANCE V	天秤V	1
17		225-05705	TIMING BELT	タイミングベルト	1
18		401-72146	AC_SERVO_MOTOR	主モータ	1
19		SL-6052092-TN	SCREW	座金付き六角穴付ボルト	3
20		236-04200	MAIN SHAFT BEARING SUPPORT	上軸ベアリング受	1
21		236-04200	MAIN SHAFT BEARING SUPPORT	上軸ベアリング受	1
22		SM-8060812-TP	SCREW M6 L=8	止めねじ M6 L=8	4
23		401-60261	UPPER_SHAFT_SPROCKET	上軸スプロケット	1
24		SM-8060812-TP	SCREW M6 L=8	止めねじ M6 L=8	2
25		225-08006	NEEDLE BAR CONNECTION GUIDE	針棒抱き案内	1
26		SS-4110915-SP	SCREW 11/64-40 L=9	なべねじ 11/64-40 L=9	2
27		400-10281	NEEDLE ROD CRANK ROD GUIDE	針棒クランクロッド案内	1
28		SS-4110915-SP	SCREW 11/64-40 L=9	なべねじ 11/64-40 L=9	2
29		235-28755	NEEDLE ROD CRANK ROD ASM.	針棒クランクロッド(組)	1
30		235-28706	NEEDLE ROD CRANK ROD	針棒クランクロッド	(1)
31		SB-1080019-00	BEARING	ころがり軸受	(2)
32		400-70532	NEEDLE_BAR_CONNECTION_ASM.	針棒抱き組	1
33		400-56873	NEEDLE BAR CONNECTION	針棒抱き	(1)
34		SS-7090910-TP	SCREW 9/64-40 L=8.5	丸平ねじ 9/64-40 L=8.5	(1)
35	#01	225-07701	THRED RACK RIGHT	針棒糸掛け 右	1
36		SS-7080520-SP	SCREW 1/8-44 L=4.9	丸平ねじ 1/8-44 L=4.9	1
37	#01	225-07404	THREAD RACK	針棒糸掛け	1
38	#01	SS-7060310-SP	SCREW 3/32-56 L=3	丸平ねじ 3/32-56 L=3	1
39	#01	MC-2005F07-00	NEEDLE 134SUK 70	針 134SUK 70	1
40	#01	MDP-500B1000	NEEDLE DPX5 #10	針 DPX5 #10	1
41		235-29159	NEEDLE ROD SUPPORT BASE ASM.	針棒支持台(組)	1
42		235-29100	NEEDLE ROD SUPPORT BASE	針棒支持台	(1)
43		235-29209	NEEDLE ROD SUPPORT BASE SHAFT	針棒支持台軸	(1)
44		235-29308	SUPPORT BASE GUIDE SHAFT	針棒支持台案内軸	(1)
45		235-29506	NEEDLE ROD METAL	針棒メタル	(2)
46		235-29407	NEEDLE ROD SUPPORT BASE FELT	針棒支持台フェルト	(1)
47		PS-0400222-K0	SPRING PIN	スプリングピン	(1)
48		SS-8120740-SP	SCREW 3/16-28 L=7	止めねじ 3/16-28 L=7	(1)
49		400-10297	SUPPORT BASE GUIDE PIN A	針棒支持台ガイドピンA	1
50		RO-0371801-00	RUBBER RING	Oリング	1
51		400-10296	SUPPORT BASE GUIDE PIN B	針棒支持台ガイドピンB	1
52		SS-8151230-SP	SCREW 15/64-28 L=12	止めねじ 15/64-28 L=12	1
53		400-03618	METAL B	針棒支持台軸後メタルB	1
54		235-44901	THRUST BUSH	針棒支持台軸スラストブッシュ	2
55		235-31114	SUPPORT BASE SHAFT REAR METAL	針棒支持台軸後メタルA	2
56		400-10315	SUPPORT BASE SHAFT FRONT METAL	針棒支持台軸前メタル	1
57		400-10322	SPRING	針棒支持台軸後メタルB押しばね	1
58		SM-8061212-TP	SCREW M6X12	止めねじ M6 L=12	1
59		WP-0720516-SD	PLAIN WASHER	平座金	1
60		NM-6060001-SC	NUT M6	六角ナット M6 1種	1
61		SB-1200008-C0	BEARING	ころがり軸受	1
62		402-09341	NEEDLE_BAR_D	針棒	1
63		EA-9500B01-00	CABLE BAND	束線バンド	1
		NOTE(注記)	#01...VARIOUS NOS.FOR DESTINATIONS	仕向地により異なる	

## 5. NEEDLE VIBRATOR COMPONENTS

針振り関係

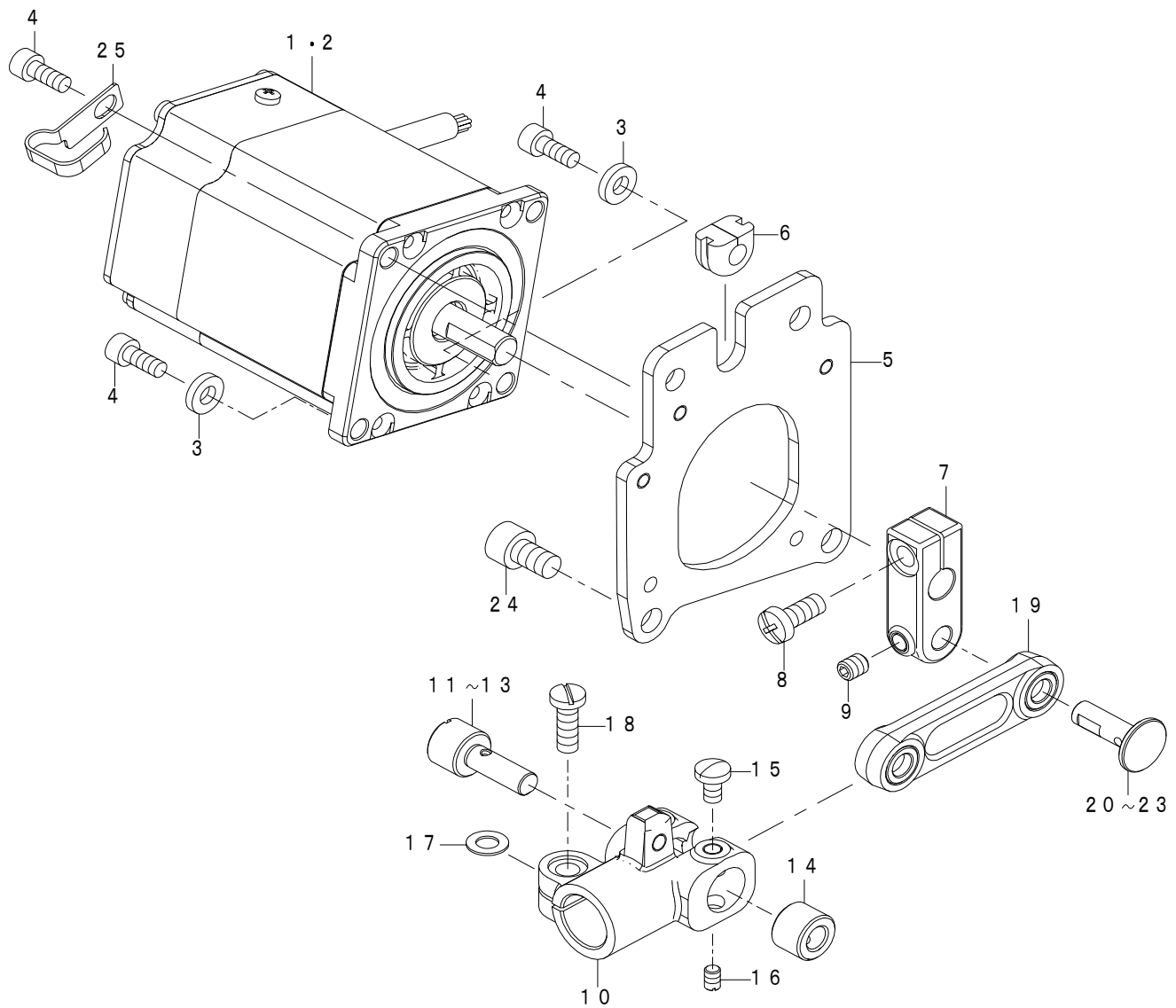

REF.NO	NOTE	PART NO	DESCRIPTION	品名	Qty
1	#02	402-19941	NEEDLE VIBRATOR MOTOR CS	針振りモータ_CS	1
2	#03	402-19867	NEEDLE VIBRATOR MOTOR CF	針振りモータ_CF	1
3		WP-0482016-SZ	WASHER	平座金	2
4		SM-6041002-TP	SCREW M4 L=10	六角ボルト M4X0.7 L=10	4
5		402-09312	NEEDLE_VIBRATOR_UNIT_BASE	針振りモータ土台	1
6		GPK-26023000	BUSH A	コードブッシュA	1
7		400-10278	MOTOR LINK	モータリンク	1
8		SM-4051255-SP	SCREW M5 L=12	なべねじ M5 L=12	1
9		SM-8050612-TP	SCREW M5X6	止めねじ M5X0.8 L=6	1
10		400-08118	SUPPORT BASE SHAFT CONNECTION	針棒支持台軸抱き	1
11	#01	400-08119	JUNCTION SHAFT A	針棒支持台軸抱きピンA	1
12	#01	400-08120	JUNCTION SHAFT B	針棒支持台軸抱きピンB	1
13	#01	400-08121	JUNCTION SHAFT C	針棒支持台軸抱きピンC	1
14		400-10298	JUNCTION SHAFT COLLAR	針棒支持台軸抱きピンカラー	1
15		SS-7110740-TP	SCREW 11/64-40 L=7	丸平ねじ 11/64-40 L=7	2
16		SS-8090670-SP	SCREW 9/64-40 L=5.5	止めねじ 9/64-40 L=5.5	1
17		WP-0520656-SA	WASHER 5.2X9.5X0.6	平ねじ 5.2X9.5X0.6	1
18		SS-7121410-TP	SCREW 3/16-28 L=14	丸平ねじ 3/16-28 L=14	1
19		400-08169	SHAFT CONNECTION LINK	針棒支持台軸抱きリンク	1
20	#01	400-10286	JUNCTION SHAFT A	針振り連結軸A	1
21	#01	400-10287	JUNCTION SHAFT B	針振り連結軸B	1
22	#01	400-10288	JUNCTION SHAFT C	針振り連結軸C	1
23	#01	400-10289	JUNCTION SHAFT D	針振り連結軸D	1
24		SM-6061002-TP	SCREW M6 L=10	六角穴ボルト M6 L=10	3
25		400-22407	CORD HOLDER	コード押え	2
		NOTE(注記)	#01....SELECTIVE PARTS	選択部品	
			#02....FOR LZ-2290CS	LZ-2290CS用	
			#03....FOR LZ-2290CF	LZ-2290CF用	

## 6. HAND LIFTER COMPONENTS

押え上げ関係

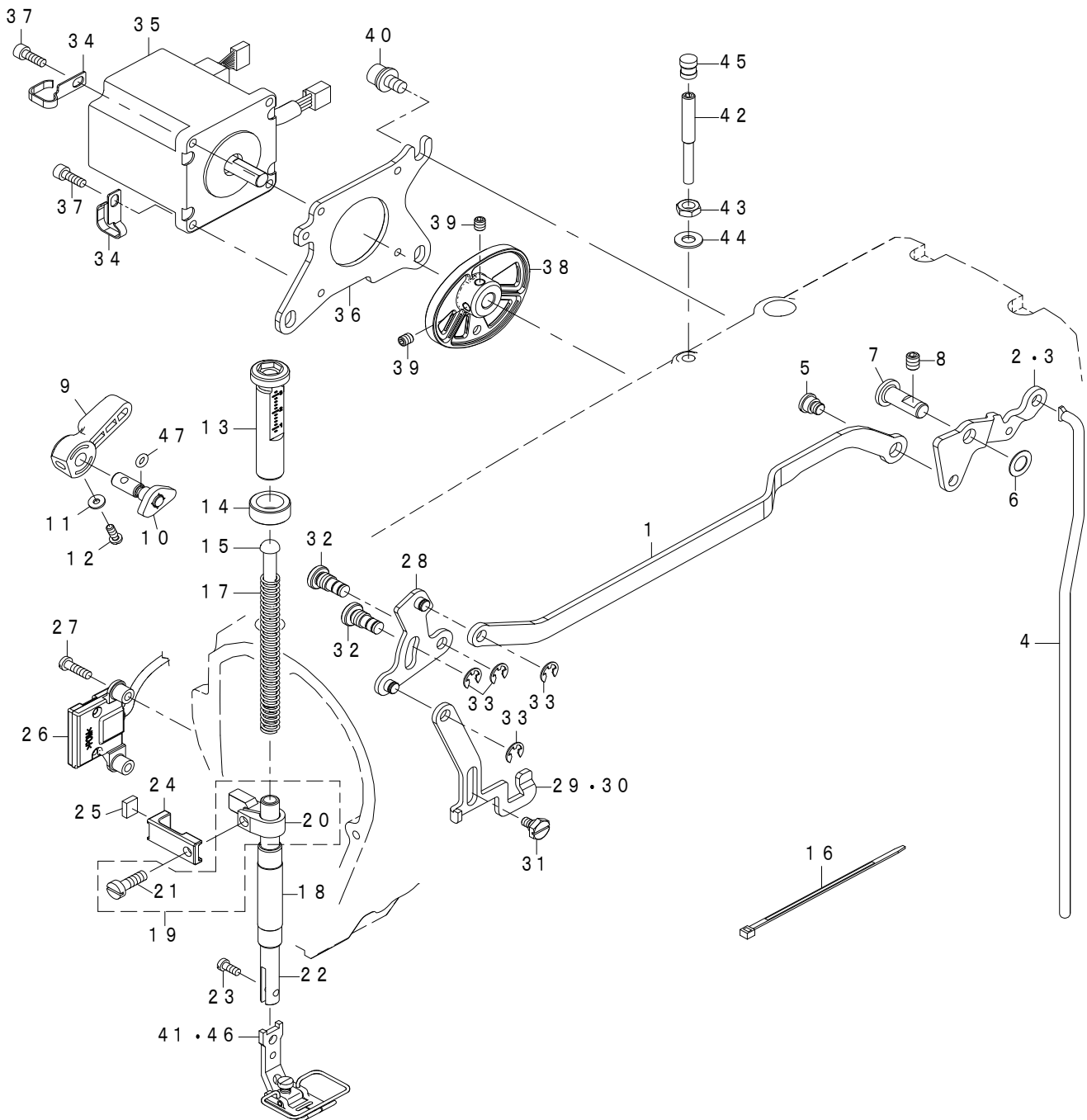



REF.NO	NOTE	PART NO	DESCRIPTION	品名	Qty
1		402-09333	KNEE_LIFTING_LINK	膝上げリンク	1
2	#01	401-72401	AK_LEVER	A Kレバー	1
3	#02	401-74615	AK_LEVER_ASSY	A Kレバー組	1
4		402-09332	CONNECTING_ROD	連結ロッド	1
5		401-74388	HINGE_SCREW	膝上げ横棒段ねじ	1
6		WP-0820526-SD	WASHER 8.2X14X0.5	平座金 8.2 X 14 X 0.5	1
7		401-72402	PRESSER_LEVER_SHAFT	押えレバー支点軸	1
8		SM-80608A2-TP	SCREW M6 L=8	六角穴付き止めねじ M6 L=8	1
9		229-07802	HAND LIFTER	押え上げレバー	1
10		229-08552	HAND LIFTER CAM ASM.	押え上げカム (組)	1
11		WP-0740516-SP	WASHER 7.4X11.8X0.5	平座金 7.4 X 11.8 X 0.5	1
12		B1521-555-000	SCREW	押え上げレバー止めねじ	1
13		236-09209	PRESSER_SPRING_REGULATOR	押え調節ねじ	1
14		229-07604	PRESSER_SPRING_REGULATOR_NUT	押え調節ねじナット	1
15		229-07703	PRESSER_GUIDE_BAR	押え案内棒	1
16		EA-9500B01-00	CABLE_BAND	束線バンド	1
17		229-07406	PRESSER_SPRING	押え調節ばね	1
18		229-07109	PRESSER_BAR_BUSHING_LOWER	押え棒下メタル	1
19		400-86606	PRESSER_BAR_GUIDE_BRACKET_ASM.	押え棒抱き組	1
20		400-86607	PRESSER_BAR_GUIDE_BRACKET	押え棒抱き	(1)
21		SM-6051400-SP	SCREW	平ねじ	(1)
22		401-25469	PRESSER_BAR	押え棒	1
23		SS-7090910-TP	SCREW 9/64-40 L=8.5	丸平ねじ 9/64-40 L=8.5	1
24	#03	402-09310	MAGNET_BASE	マグネット土台	1
25	#03	401-72415	MAGNET	磁石	1
26	#03	402-11903	CLOTH_PRESSER_SENSOR_ASM	布押えセンサー組	1
27	#03	SM-4041455-SN	SCREW M4 L=14	なべねじ M4 L=14	2
28		229-08156	LIFTING_LINK_ASM.	引き上げリンク (組)	1
29	#04	402-09330	LIFTING_LEVER	押え上げレバー	1
30	#03	402-09342	LIFTING_LEVER_AT	押え上げリンク (A T用)	1
31		SD-0630275-SP	HINGE_SCREW D=6.35 H=2.7	段ねじ D=6.35 H=2.7	1
32		229-08701	LINK_SHAFT	押え上げリンク軸	2
33		RE-0500000-K0	E-RING	E形止め輪 5	4
34		400-22407	CORD HOLDER	コード押え	2
35		401-68923	PRESSER MOTOR	押えモータ	1
36		402-09343	LIFTER_MOTOR_BASE	押え上げモーター土台	1
37		SM-6041202-TP	SCREW M4X0.7 L=12	六角穴ボルト	4
38		401-74375	CAM	カム	1
39		SM-80508A2-TP	SCREW M5 L=8	六角穴付き止めねじ M5 L=8	2
40		SL-6061292-TN	SCREW	座金付き六角穴ボルト	3
41	#05	401-38514	PRESSER FOOT ASM.	押え (組)	1
42		400-36706	ADJUSTING SCREW	微量押え上げねじ	1
43		NM-6060003-SE	NUT FOR BRACKET	六角ナット M6 2種	1
44		WP-0621016-SD	WASHER 6.2X13X1	平座金 6.2 X 13 X 1	1
45		182-00501	WORK ATTACHMENT (SMALL)	ワークアタッチメント (小)	1
46	#05	225-84965	PRESSER FOOT ASM.	押え (組)	1
47		RO-0371801-00	RUBBER RING	Oリング	1
		NOTE(注記)	#01...WITH OUT AK #02...WITH AK #03...FOR LZ-2290CF #04...FOR LZ-2290CS #05...VARIOUS NOS.FOR DESTINATIONS	A K なし A K あり L Z - 2 2 9 0 C F 用 L Z - 2 2 9 0 C S 用 仕向地により異なる	

## 7. HAND LIFTER COMPONENTS (AK156)

押え上げ関係 (AK 156)

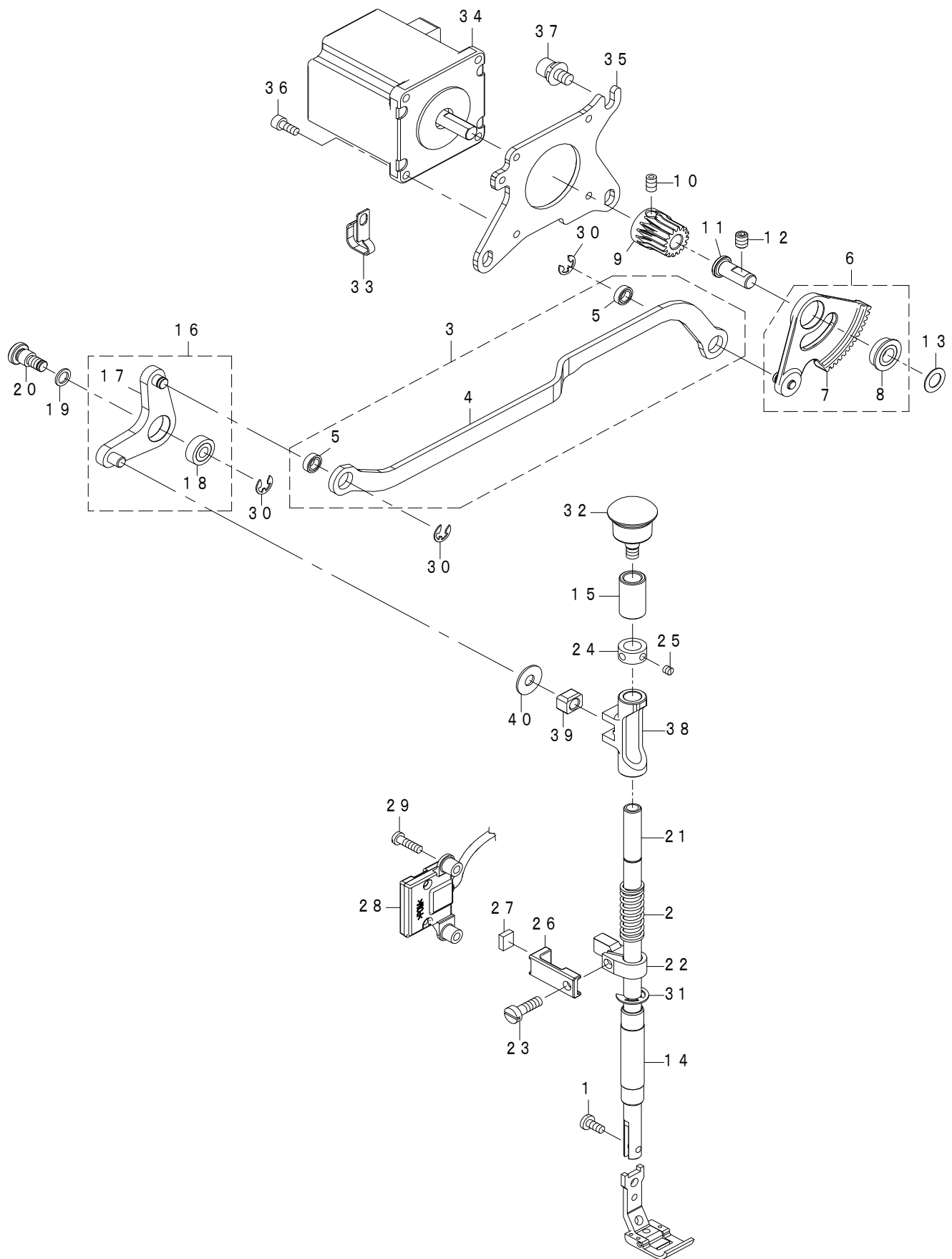

REF.NO	NOTE	PART NO	DESCRIPTION	品名	Qty
1		SS-7090910-TP	SCREW 9/64-40 L= 8.5	丸平ねじ 9/64-40 L=8.5	1
2		402-26017	PRESSER_SPRING_M	押えばねM	1
3		402-26006	PRESSER_LINK_A_ASM	押えリンクA (組)	1
4		402-26007	PRESSER_LINK_A	押えリンクA	(1)
5		SB-1060005-00	BEARING	スロートベアリング	(2)
6		402-26003	PRESSER_GEAR_COMP_N	押えギヤ(組合)N	1
7		402-26004	PRESSER_GEAR_ASM_N	押えギヤ(組)N	(1)
8		SB-1080002-00	SIDE BEARING	サイドベアリング	(1)
9		402-00004	MOTOR_GEAR_N	モータギヤN	1
10		SM-80508A2-TP	SCREW M5 L=8	六角穴付き止めねじ M5 L=8	2
11		401-72402	PRESSER_LEVER_SHAFT	押えレバー支点軸	1
12		SM-80608A2-TP	SCREW M6 L=8	六角穴付き止めねじ M6 L=8	1
13		WP-0820526-SD	WASHER 8.2X14X0.5	平座金 8.2X14X0.5	1
14		229-07109	PRESSER_BAR BUSHING, LOWER	押え棒下メタル	1
15		402-26021	BUSH_A	押え棒上メタル	1
16		402-26018	ASSY_PRESSER_LINK_B	押えリンクB(組)	1
17		402-26019	ASSY_PRESSER_LINK_B_A	押えリンクB(組)A	(1)
18		SB-1060004-00	CLUTCH BEARING	クラッチベアリング	(1)
19		WP-0661016-SP	WASHER	平座金	1
20		402-26008	PRESSER_LINK_SCREW	押えリンクB支点軸	1
21		402-26010	PRESSER_BAR	押え棒	1
22		402-26014	PRESSER_BAR_GUIDE_BRACKET	押え棒抱き	1
23		SM-6051400-SP	SCREW	平ねじ	1
24		402-26020	THRUST_COLLAR	スラスト受	1
25		SS-8110410-TP	SCREW 11/64-40 L= 3.5	止めねじ 11/64-40 L=3.5	2
26		402-09310	MAGNET_BASE	マグネット玉台	1
27		401-72415	MAGNET	磁石	1
28		402-11903	CLOTH_PRESSER_SENSOR_ASM	布押えセンサー組	1
29		SM-4041455-SN	SCREW M4 L=14	なべねじ M4 L=14	2
30		RE-0500000-K0	E-RING	E形止め輪 5	3
31		RE-0800000-K0	E-SHAPED SNAP RING (8MM)	E形止め輪 8	1
32		401-72389	CAP	押え棒上メタルカバー	1
33		400-22407	CORD HOLDER	コード押え	3
34		401-68923	PRESSER MOTOR	押えモータ	1
35		402-09343	LIFTER_MOTOR_BASE	押え上げモーター土台	1
36		SM-6041002-TP	SCREW M4X0.7 L=10	六角穴ボルト M4X0.7 L=10	4
37		SL-6061292-TN	SCREW	座金付き六角穴ボルト	3
38		402-26009	PRESSER_GUIDE_BOSS	押え上下ガイド	1
39		401-41757	SQUARE_BLOCK	角駒	1
40		WP-0621036-SP	WASHER	平座金	1

# 8. FEED MECHANISM COMPONENTS

送り関係

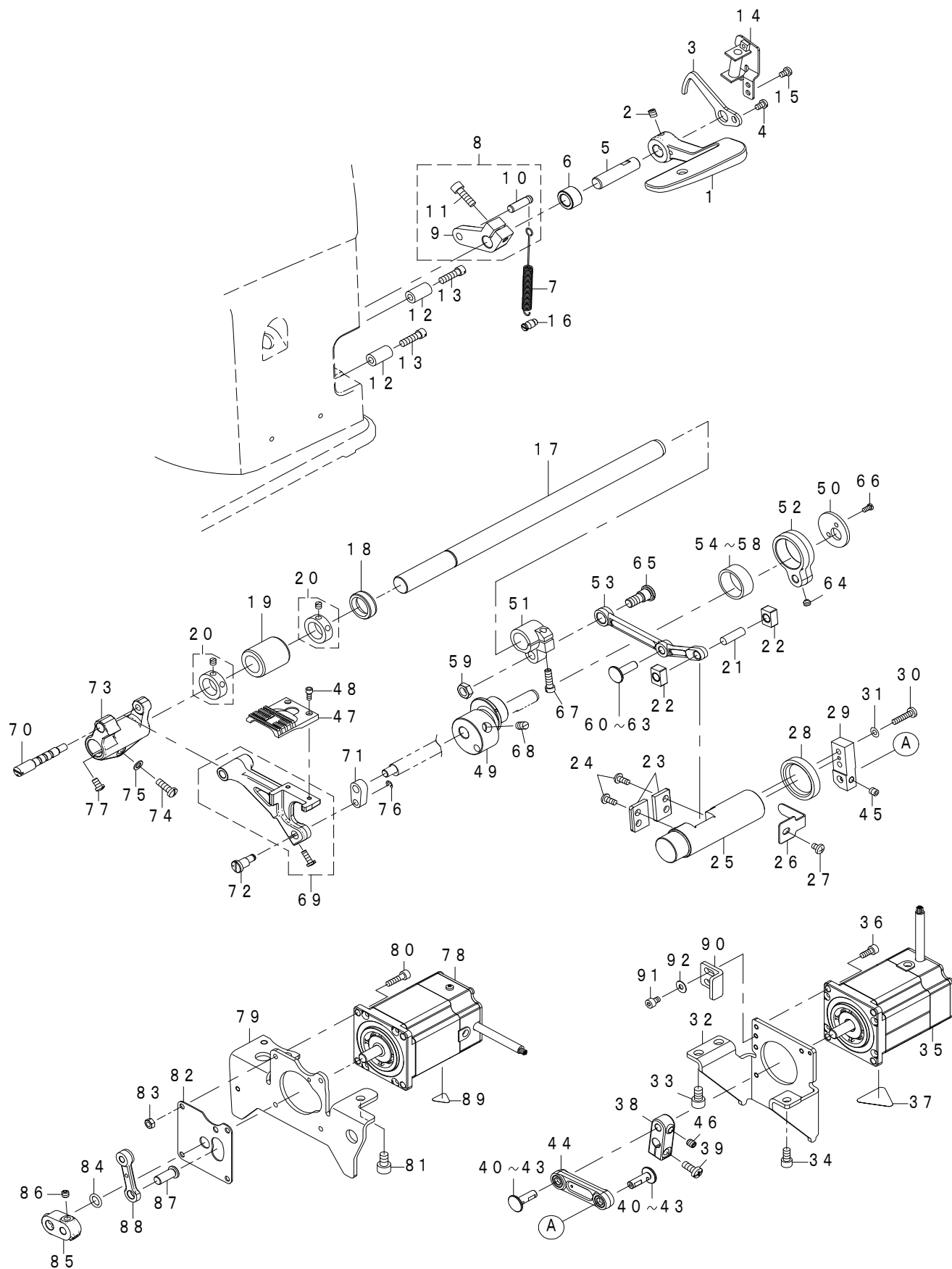

REF.NO	NOTE	PART NO	DESCRIPTION	品名	Qty
1		401-72378	REVERSE_FEED_LEVER	逆送りレバー	1
2		SM-8050612-TP	SCREW M5X6	逆送りレバー止めねじ	2
3		401-74291	FEED_CONTROL_SENSOR_PLATE	逆送りセンサー板	1
4		SM-4040655-SP	SCREW	逆送りセンサー板固定ねじ	1
5		401-72509	FEED_LEVER_SHAFT	送りレバー軸	1
6		401-72510	FEED_LEVER_SHAFT_METAL	送りレバー軸メタル	1
7		110-50705	LEVER_RETURN_SPRING	送りレバーばね	1
8		401-74293	ASSY_FEED_LEVER_ARM	送りレバー腕(組)	1
9		401-74294	FEED_LEVER_ARM	送りレバー腕	(1)
10		229-12307	PIN	送りレバー腕ピン	(1)
11		SM-6051602-TP	SCREW M5X0.8 L=16	六角穴ボルト M5X0.8 L=16	(1)
12		229-52501	BACK_LEVER_STOPPER	逆送りレバーストッパー	2
13		SM-6051850-TP	SCREW M5 L=18	逆送りレバーストッパー止めねじ	2
14		401-74405	FEED_CONTROL_SENSOR_BASE_ASM	逆送りセンサー台(組)	1
15		SM-4040655-SP	SCREW	逆送りセンサー台止めねじ	2
16		400-38494	THREAD_BIND_ARM_SPRING_RAC	逆送りレバーばね掛け	1
17		400-10311	HORIZONTAL_FEED_SHAFT	水平送り軸	1
18		401-39216	OIL_SEAL	送り軸オイルシール	1
19		236-16709	FEED_ROCKER_SHAFT_METAL	水平送り軸メタル	1
20		CS-1470710-SH	THRUST_COLLAR_ASM.D=14.72 W=7	送り軸スラスト受け	2
21		400-32271	PIN	角駒ピン	1
22		400-50457	FEED_DRIVING_ROCKER_BLOCK	送り調節体角駒	2
23		263-03404	CAP	送り調節体蓋	2
24		SS-4110915-SP	SCREW 11/64-40 L=9	送り調節体蓋止めねじ	4
25		400-10318	FEED_ADJUSTING_A	送り調節体	1
26		235-32203	FEED_ADJUSTING_PRESSER	送り調節体押え	1
27		SS-4110615-SP	SCREW 11/64-40 L=6	送り調節体押え止めねじ	1
28		235-32005	FEED_ADJUSTING_OIL_SEAL	送り調節体オイルシール	1
29		400-11837	PULSE_MOTOR_LINK_C	パルスモーターリンクC	1
30		SS-7111810-TP	SCREW 11/64-40 L=18	パルスモーターリンクC止めねじ	2
31		WP-0460556-SD	WASHER 4.6X7.5X0.5	パルスモーターリンクC止めねじ座金	2
32		402-09356	HORIZONTAL_MOTOR_BASE	水平送りパルスモーター土台	1
33		SM-6061002-TP	SCREW M6 L=10	水平送りパルスモーター土台止めねじ	2
34		SM-6051002-TP	SCREW M5X0.8 L=10	水平送りパルスモーター土台止めねじ	1
35		401-68921	STEPPING_MOTOR	水平送りパルスモーター	1
36		SM-6041002-TP	SCREW M4X0.7 L=10	送りパルスモーター止めねじ	4
37		CM-3003000-03	HIGH_TEMPARATURE_CAUTION_LABEL_2(31.5)	水平送りモータ高温注意シール	1
38		400-10278	PULSE_MOTOR_LINK_B	パルスモーターリンクB	1
39		SM-4051655-SP	SCREW M5 L=16	パルスモーターリンクB締めねじ	1
40	#01	400-10286	JUNCTION_SHAFT_A	針振り連結軸A	2
41	#01	400-10287	JUNCTION_SHAFT_B	針振り連結軸B	2
42	#01	400-10288	JUNCTION_SHAFT_C	針振り連結軸C	2
43	#01	400-10289	JUNCTION_SHAFT_D	針振り連結軸D	2
44		400-08169	ASSY_PULSE_MOTOR_LINK_A	パルスモーターリンクA(組)	1
45		SM-8050612-TP	SCREW M5X6	送り調節体偏心軸止めねじ	2
46		SM-8050612-TP	SCREW M5X6	パルスモーターリンクピン止めねじ	1
47	☆	225-81508	FEED_DOG	送り	1
48		SS-6580752-TP	SCREW 1/8-40 L=7	送り止めねじ	2
49		401-49246	HORIZONTAL_FEED_CAM	水平送りカム	1
50		235-32401	HORIZONTAL_FEED_CAM_COVER	水平送りカム蓋	1
51		B1608-555-0A0	FEED_ROCKER_SHAFT_CRANK_ASM.	水平送り腕(組)	1
52		401-25487	HORIZONTAL_FEED_ROD	水平送りロッド	1
53		401-25488	CONNECTING_ROD	水平送り連結桿	1
54	#01	SB-3220002-CA	BEARING	ころがり軸受	1
55	#01	SB-3220002-CB	BEARING	ころがり軸受	1
56	#01	SB-3220002-CC	BEARING	ころがり軸受	1
57	#01	SB-3220002-CD	BEARING	ころがり軸受	1
58	#01	SB-3220002-CE	BEARING	ころがり軸受	1
59		NS-6680410-SP	HEXAGONAL_NUT_9/32-28	水平送り連結桿ナット	2
60	#01	400-10286	JUNCTION_SHAFT_A	針振り連結軸A	1
61	#01	400-10287	JUNCTION_SHAFT_B	針振り連結軸B	1
62	#01	400-10288	JUNCTION_SHAFT_C	針振り連結軸C	1
63	#01	400-10289	JUNCTION_SHAFT_D	針振り連結軸D	1
64		SM-8050402-TP	SCREW	水平送り連結桿ピン止めねじ	1
65		SD-0900701-TP	SHOULDER_SCREW_D=9 H=7	水平送り連結桿段ねじ	2
66		SS-4080620-TP	SCREW 1/8-44 L=6	水平送りカム蓋止めねじ	2
67		SS-6121610-TP	SCREW 3/16-28 L=15.5	水平送り腕締めねじ	1
68		SS-8660810-TP	SCREW 1/4-40 L=8	水平送りカム止めねじ	2
69		401-25481	FEED_BASE_ASM	送り台(組)	1
70		401-25485	FEED_BASE_SHAFT	送り台軸	1
71	#02	401-25483	VERTICAL_FEED_LINK	上下送りリンク	1
72		263-03107	VERTICAL_FEED_LINK_SHAFT_D	上下送りリンク軸D	1
73		229-40654	FEED_ROCKER	送り台腕	1
74		SS-7121410-TP	SCREW 3/16-28 L=14	丸平ねじ 3/16-28 L=14	1
75		WP-0480856-SP	WASHER 4.8X8.4X0.8	平座金 4.8X8.4X0.8	1
76		RE-0300000-K0	E-RING_3	上下送りリンク軸Eリング	1
77		SS-7110740-TP	SCREW 11/64-40 L=7	送り台腕締めねじ	1
78	#03	401-68922	STEPPING_MOTOR	上下送りパルスモーター	1
79	#03	402-09318	VERTICAL_MOTOR_BASE	上下送りモータ土台	1
80	#03	SM-6041602-TP	SCREW M4X0.7 L=16	上下送りパルスモーター固定ねじ	4
81	#03	SM-6061002-TP	SCREW M6 L=10	上下モータ土台固定ねじ	2
82	#03	402-09317	FEED_MOTOR_CAP	上下送りモータ油防板	1
83	#03	NM-6040000-SN	NUT M4 TYPE1	上下送りモータ油防板固定ナット	4
84	#03	RO-0781901-00	O-RING	上下送りモータOリング	1
85	#03	402-09355	MOTOR_LEVER	上下送りモータリンクA	1
86	#03	SM-8050502-TP	SCREW M5 L=5	上下送りモータリンクA止めねじ	4
87	#03	400-86699	REVERSE_FEED_LINK_PIN	上下送りモータリンクピン	1
88	#03	402-09316	FEED_CONNECT_LINK	上下送りモータリンクB	1
89	#03	CM-3003000-01	HIGH_TEMPARATURE_CAUTION_LABEL_2(16)	上下送りモータ高温注意シール	1
90		402-20000	STOPPER	ストップ	1
91		SM-6040602-TP	SCREW M4X0.7 L=6	六角穴ボルト M4X0.7 L=6	2
92		WP-0410516-SD	PLAIN_WASHER	平座金 4.1X10X0.5	2
		NOTE(注記)	#01....SELECTIVE PARTS #02....FOR LZ-2290CS #03....FOR LZ-2290CF	選択部品 LZ-2290CS用 LZ-2290CF用	

# 9. HOOK DRIVING SHAFT COMPONENTS (1)

下軸関係 (1)

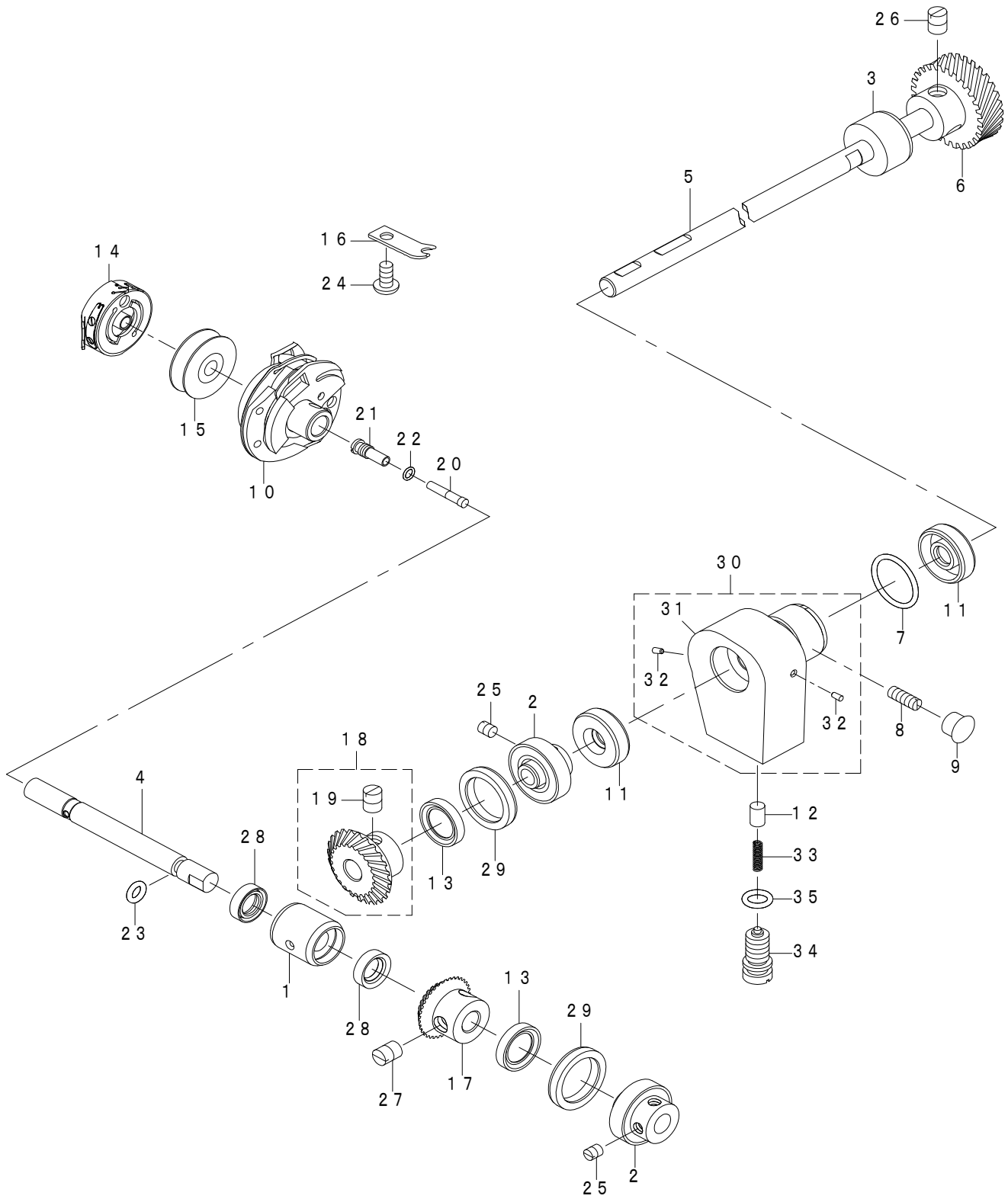

REF.NO	NOTE	PART NO	DESCRIPTION	品名	Qty
1		235-35107	HOOK SHAFT FRONT METAL	釜軸前メタル	1
2		400-03590	HOOK SHAFT BEARING ASM.	釜軸軸受(組)	2
3		235-35602	HOOK DRIVING SHAFT REAR METAL	釜駆動軸後メタル	1
4		400-10283	HOOK SHAFT	釜軸	1
5		402-09319	HOOK_DRIVING_SHAFT	釜駆動軸	1
6		100-31003	HELICAL GEAR B	釜駆動歯車B	1
7		RO-1721801-00	RUBBER RING	Oリング	1
8		SS-8111251-SP	SCREW 11/64-40 L=12.0	止めねじ 11/64-40 L=12	1
9		TA-0850604-R0	RUBBER PLUG	止め栓	1
10	☆	225-25877	HOOK COMPL. V	釜結合V	1
11		228-90008	HOOK DRIVING SHAFT OIL SEAL	下軸オイルシール	2
12		236-28803	PLUNGER	プランジャー	1
13		400-11424	HOOK GEAR BOX OIL SEAL	釜ギヤボックスオイルシール	2
14	☆	401-25507	BOBBIN CASE ASM.	ボビンケース(組)	1
15	☆	225-96704	BOBBIN S	ボビン S	1
16		235-03402	INNER HOOK STOPPER	内釜止め	1
17		B1308-155-000	MITRE GEAR SMALL	下傘歯車(小)	1
18		B1307-155-0A0	GEAR ASM. LARGE	下傘歯車(大)組	1
19		SS-8660810-TP	SCREW 1/4-40 L=8	止めねじ 1/4-40 L=8	(2)
20		110-15906	OIL WICK	シモジクマエトメネジユシン	1
21		229-16506	SET SCREW	下軸前止めねじ	1
22		RO-0360802-00	RUBBER RING	Oリング	1
23		RO-0481901-00	RUBBER RING	Oリング	1
24		SS-4110915-SP	SCREW 11/64-40 L=9	なべねじ 11/64-40 L=9	1
25		SS-8110520-TP	SCREW 11/64-40 L=4.5	止めねじ 11/64-40 L=4.5	4
26		SS-8660810-TP	SCREW 1/4-40 L=8	止めねじ 1/4-40 L=8	2
27		SS-8660810-TP	SCREW 1/4-40 L=8	止めねじ 1/4-40 L=8	2
28		401-20730	HOOK SHAFT OIL SEAL	釜軸オイルシール	2
29		400-10282	OIL SEAL COLLAR	釜軸軸受オイルシールカラー	2
30		402-09344	PUMP_METAL_ASSY	ポンプメタル組	1
31		402-09345	PUMP_METAL	ポンプメタル	(1)
32		TA-0180401-M0	NEEDLE COOLER PLUG CAP	止め栓 D=1.8 X 2.1 L=4.3	(3)
33		236-28902	PLUNGER SPRING	プランジャーばね	1
34		236-29009	PLUNGER SCREW	プランジャーねじ	1
35		RO-0681901-00	RUBBER RING	Oリング	1

# 10. HOOK DRIVING SHAFT COMPONENTS (2)

下軸関係 (2)

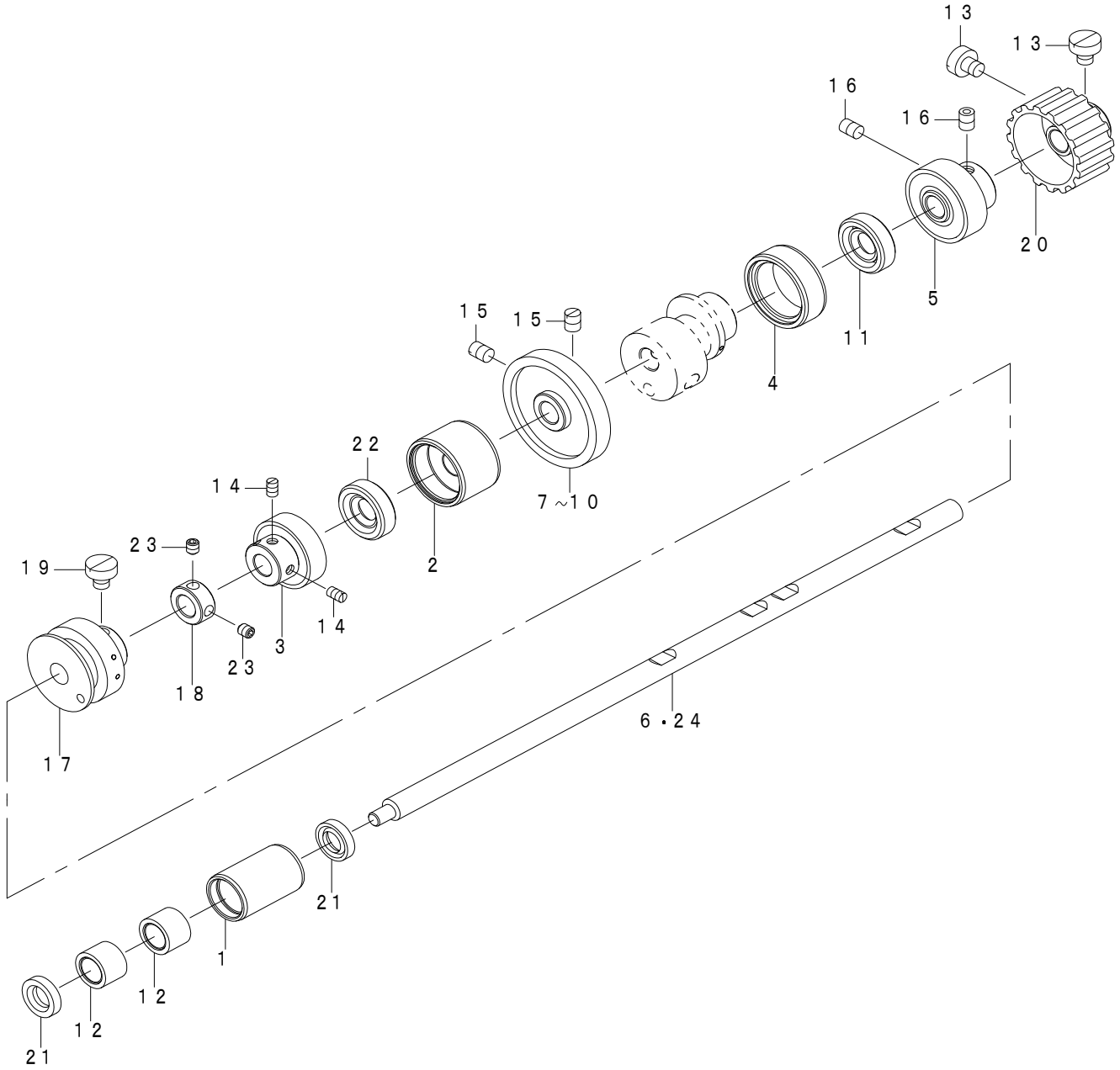



REF.NO	NOTE	PART NO	DESCRIPTION	品名	Qty
1		400-10316	LOWER SHAFT FRONT BEARING BUSH	下軸前軸受ブッシュ	1
2		400-10314	LOWER SHAFT INNER METAL	下軸中メタル	1
3		235-36055	LOWER SHAFT INNER BEARING ASM.	下軸中軸受(組)	1
4		235-36105	LOWER SHAFT REAR BUSH	下軸後ブッシュ	1
5		235-36253	LOWER SHAFT REAR BEARING ASM.	下軸後軸受(組)	1
6	#01	400-10303	LOWER SHAFT	下軸	1
7	#02	401-49251	HELICAL_GEAR_A	釜駆動歯車大A	1
8	#02	401-49252	HELICAL_GEAR_B	釜駆動歯車大B	1
9	#02	401-49253	HELICAL_GEAR_C	釜駆動歯車大C	1
10	#02	401-49254	HELICAL_GEAR_D	釜駆動歯車大D	1
11		G1615-880-000	OIL SEAL	オイルシール	1
12		SB-3100010-C0	BEARING	ころがり軸受	2
13		SS-6660710-TP	SCREW 1/4-40 L=7	平ねじ 1/4-40 L=7	2
14		SS-8110750-SP	SCREW 11/64-40 L=6.5	止めねじ 11/64-40 L=6.5	2
15		SS-8660810-TP	SCREW 1/4-40 L=8	止めねじ 1/4-40 L=8	2
16		SM-8060812-TP	SCREW M6 L=8	止めねじ M6 L=8	2
17		235-41709	THREAD TRIMMER CAM	糸切りカム	1
18		CS-1000881-TP	THRUST COLLAR	スラスト受 D=10 W=8	1
19		SS-6660710-TP	SCREW 1/4-40 L=7	平ねじ 1/4-40 L=7	2
20		401-60262	LOWER_SHAFT_SPROCKET	下軸スプロケット	1
21		B2508-704-000	OIL SEAL	ルーバ軸オイルシール	2
22		G1615-880-000	OIL SEAL	オイルシール	1
23		SM-80506A2-TP	SCREW M5 L=6	六角穴付き止めねじ M5 L=6	2
24	#03	402-09320	LOWER_SHAFT	下軸	1
		NOTE(注記)	#01....FOR LZ-2290CS	LZ-2290CS用	
			#02....SELECTIVE PARTS	選択部品	
			#03....FOR LZ-2290CF	LZ-2290CF用	

# 11. THREAD TENSION COMPONENTS (TYPE FULL DIGITAL)

糸調子関係 (フルデジタル仕様)

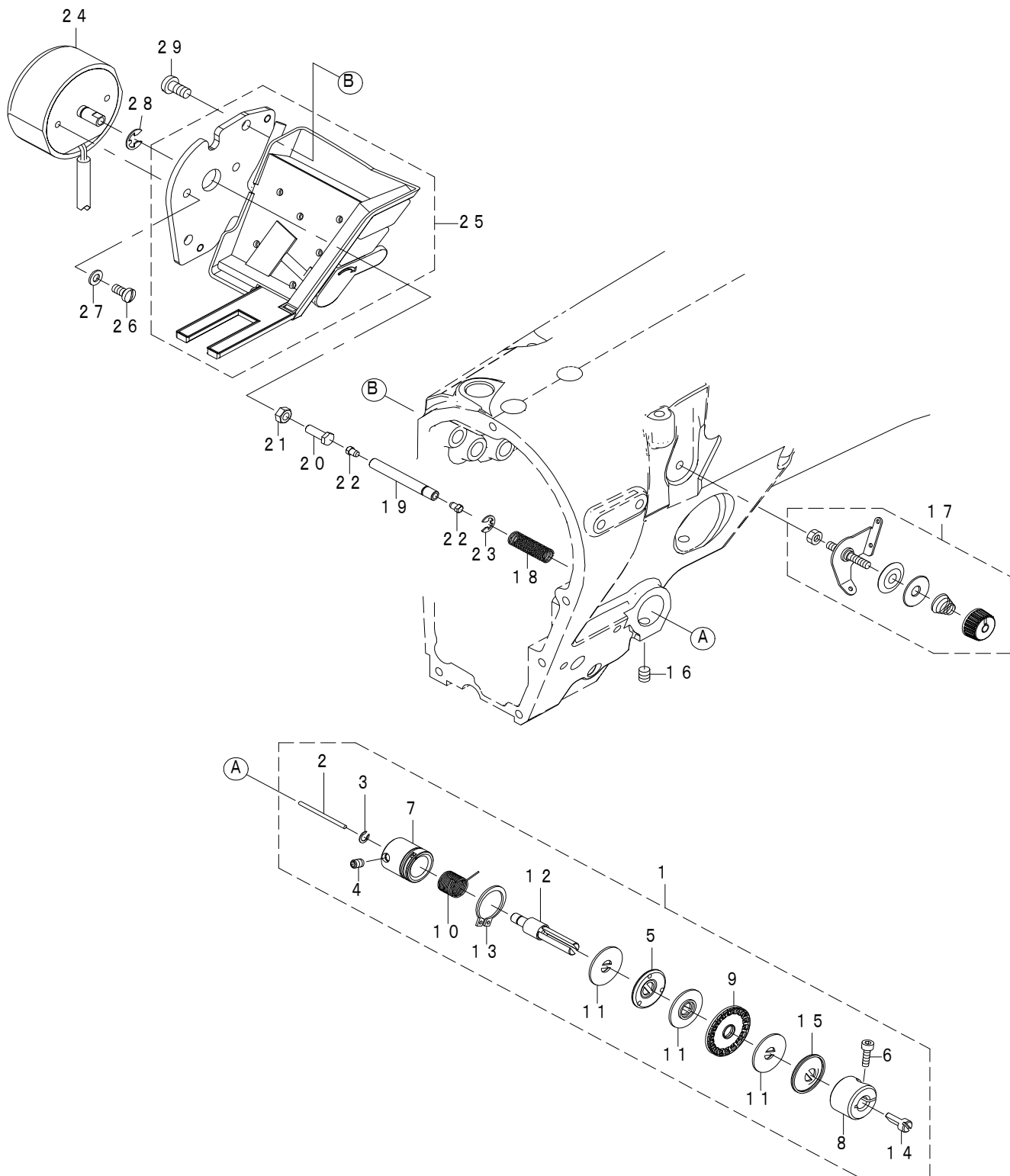

REF.NO	NOTE	PART NO	DESCRIPTION	品名	Qty
1		402-09328	AT_THREAD_TENSION_ASM	A T糸調子組	1
2		B3118-552-I00	TENSION RELEASING PIN I	糸緩めピン I	(1)
3		RC-0410415-KP	C-RING	C形止め輪	(1)
4		SM-8040612-TP	SCREW M4 L=6	止めねじ M4 L=6	(1)
5		401-26724	TENSION_DISC HOLDER	糸調子皿押え	(1)
6		SM-6031002-TN	SCREW M3 L=10	六角穴ボルト M3 L=10	(1)
7	*	402-54811	TENSION_POST_BASE_ASM	糸調子台(組)	(1)
8		401-72474	DISK_STOPPER HOLDER_CAP	糸調子キャップ	(1)
9		225-28350	THREAD TENSION DISK COMPL.	糸調子皿(結合)	(1)
10	☆	402-09339	THREAD_TAKE_UP_SPRING	A Tばね	(1)
11		402-09336	RESIN_PLATE	樹脂皿	(3)
12		401-72472	AT_SHAFT	A T糸調子棒	(1)
13		RC-1700001-KP	RETAINING RING	C形止め輪	(1)
14		401-72473	DISK_STOPPER HOLDER_CAP_PIN	糸調子キャップピン	(1)
15		B3132-012-000	TENSION DISC HOLDER	糸調子皿押え	(1)
16		SM-80506A2-TP	SCREW M5 L=6	六角穴付き止めねじ M5 L=6	1
17		401-25685	PRE-TENSION CONTROLLER ASM	プリテンション(組)	1
18		402-09353	AT_SPRING	A Tばね	1
19		401-72475	THREAD_TENSION_SHAFT	糸緩め補助ピン	1
20		401-74311	SCREW	M4ボルト	1
21		NM-6040000-SN	NUT M4	六角ナット M4	1
22		262-01004	GUIDE PIN	中釜押えガイドピン	2
23		RE-0400000-K0	E-RING 4	E形止め輪 4	1
24		402-19992	AT_SOLENOID_A	A Tソレノイド_A	1
25	☆	402-09331	LED_TB_SWITCH	3連SW	1
26		SM-7040800-SL	SCREW	丸平ねじ	2
27		WP-0410846-SC	WASHER	平座金	2
28		RE-0500000-K0	E-RING	E形止め輪 5	1
29		SM-4051055-SP	SCREW	なべねじ	2

## 12. THREAD TENSION COMPONENTS (TYPE DIGITAL)

糸調子関係 (デジタル仕様)

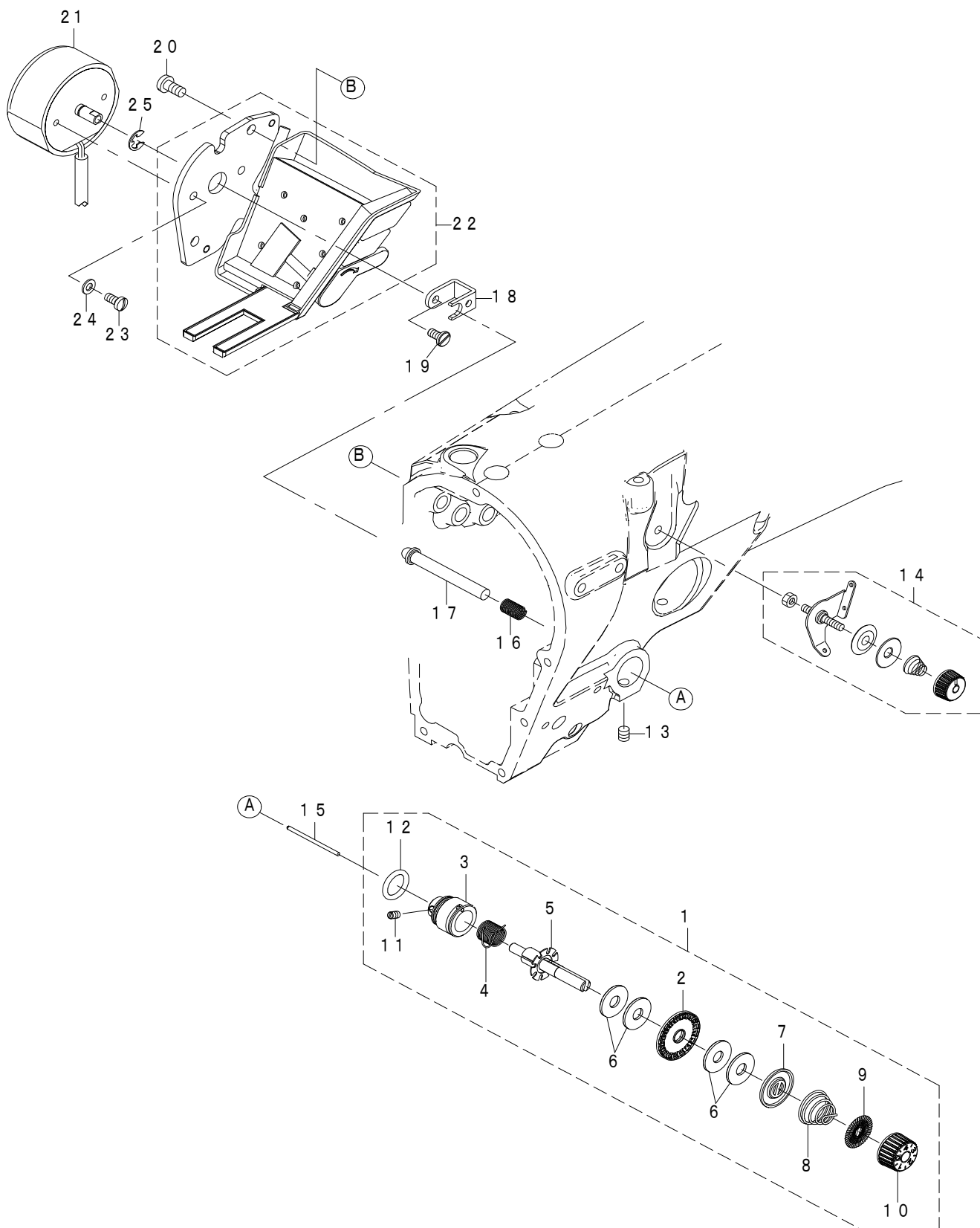

REF.NO	NOTE	PART NO	DESCRIPTION	品名	Qty
1		401-25651	THREAD_TENSION_ASM	糸調子(組)	1
2		235-47557	THREAD TENSION T COMPL.	糸調子T(結合)	(1)
3		225-28152	THREAD TENSION ROD ASM.	糸調子棒台(組)	(1)
4	☆	235-38309	THREAD TAKE-UP SPRING	糸取りばね	(1)
5		401-41101	THREAD_TENSION_POST_COMPL.	糸調子棒結合	(1)
6		225-28509	FELT	糸調子皿フェルト	(4)
7		100-06005	TENSION DISC HOLDER	糸調子皿押え	(1)
8		B3121-352-000	TENSION SPRING	上ルーパ糸調子ばね	(1)
9		229-21407	ROTATION STOPPER	糸調子皿回転止め	(1)
10		236-26005	THREAD TENSION NUT	糸調子ナット	(1)
11		SS-8090670-SP	SCREW 9/64-40 L=5.5	止めねじ 9/64-40 L=5.5	(1)
12		RO-1182401-00	O-RING	Oリング	(1)
13		SM-80506A2-TP	SCREW M5 L=6	六角穴付き止めねじ M5 L=6	1
14		401-25685	PRE-TENSION CONTROLLER ASM	プリテンション(組)	1
15		402-09416	TENSION_RELEASE_PIN	糸緩めピン	1
16		229-20409	THREAD RELEASE PIN SPRING	糸緩めピンばね	1
17		225-28616	THREAD_RELEASE	糸緩め補助ピン	1
18		402-09347	THREAD_RELEASE_PLATE	糸緩め押し板	1
19		SM-6040860-TP	SCREW M4 L=8	平ねじ M4 L=8	1
20		SM-4051055-SP	SCREW	なべねじ	2
21		402-19992	AT_SOLENOID_A	ATソレノイド_A	1
22	☆	402-09331	LED_TB_SWITCH	3連SW	1
23		SM-7040800-SL	SCREW	丸平ねじ	2
24		WP-0410846-SC	WASHER	平座金	2
25		RE-0500000-K0	E-RING	E形止め輪 5	1

### 13. THREAD FEEDER COMPONENTS

糸繰り出し関係

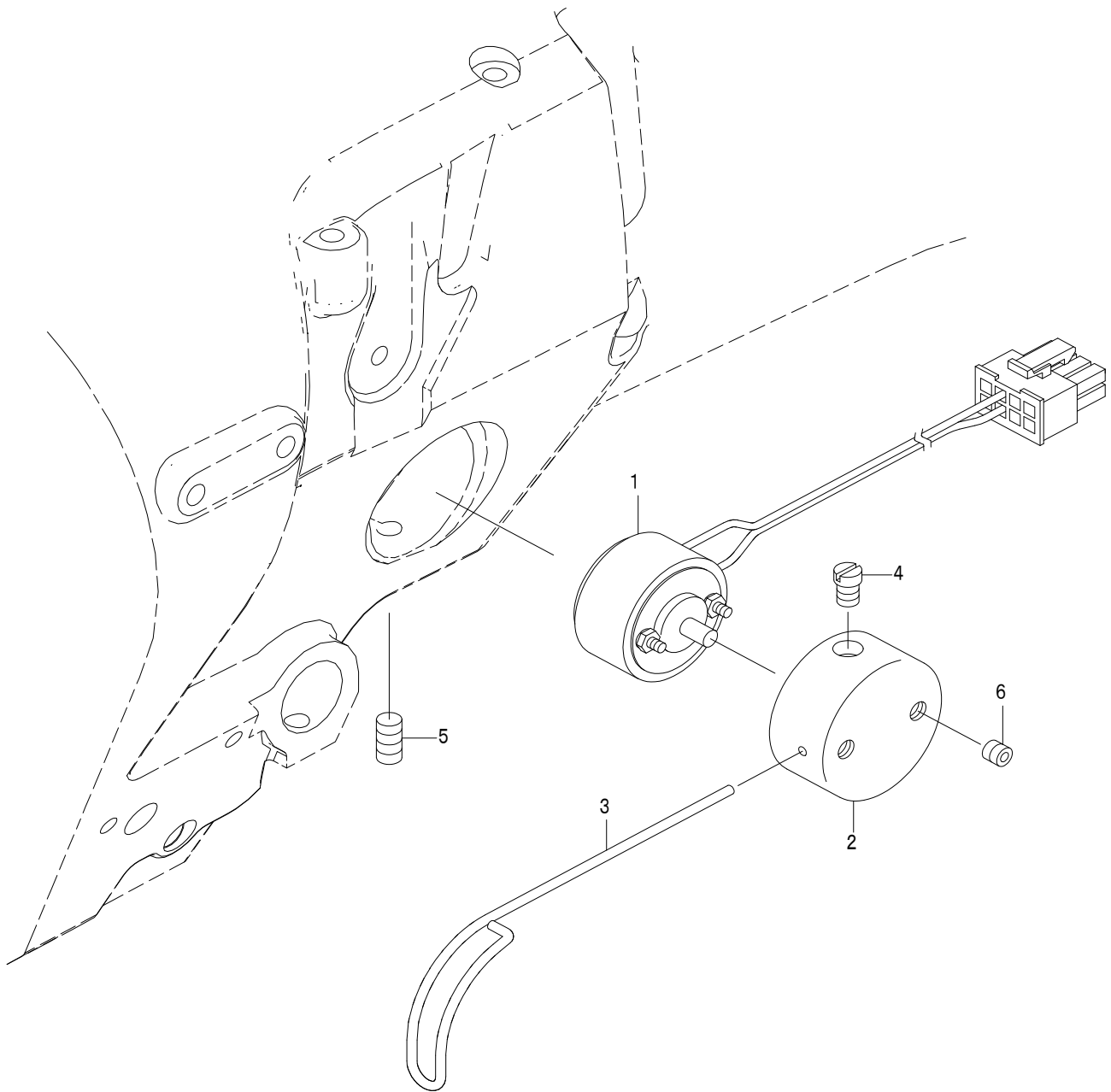

REF.NO	NOTE	PART NO	DESCRIPTION	品名	Qty
1		402-19993	FEEDER SOLENOID ASM.	繰出しソレノイド組	1
2		400-10321	FEEDER WIRE FITTING BASE	繰出しワイヤー取付台	1
3		235-38606	FEEDER WIRE	繰出しワイヤー	1
4		SS-6110710-TP	SCREW 11/64-40 L= 6.5	平ねじ 11/64-40 L=6.5	1
5		SM-8051002-TP	SCREW M5 L=10	止めねじ	1
6		SS-8110422-TP	SCREW 11/64-40 L=4	止めねじ 11/64-40 L=4	2

# 14. LUBRICATION COMPONENTS

給油関係

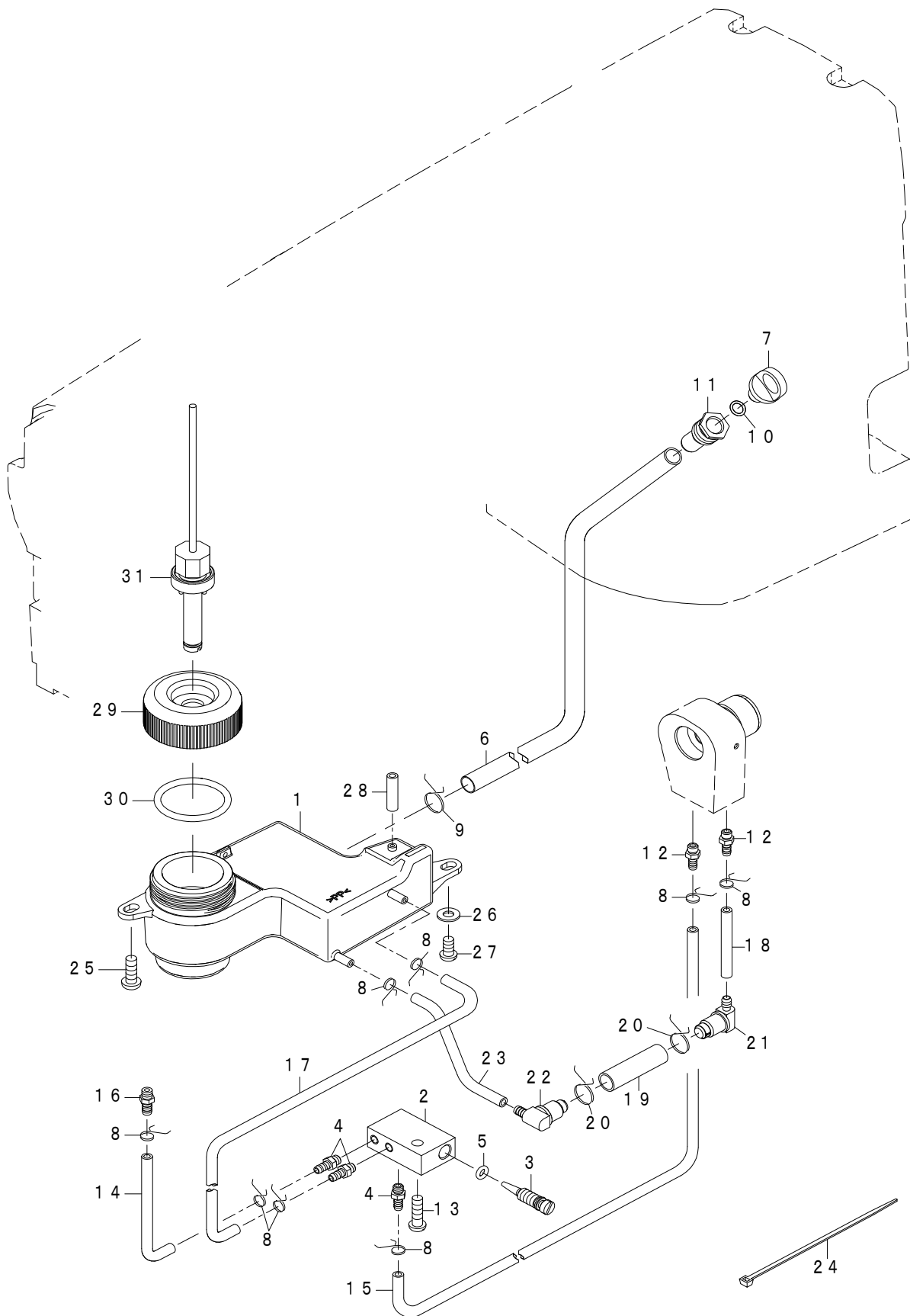



REF.NO	NOTE	PART NO	DESCRIPTION	品名	Qty
1		402-09314	OIL_TANK	オイルタンク	1
2		402-09315	HOOK_OIL_REGULATING	釜油調節器	1
3		235-39414	HOOK OIL REGULATING SCREW	釜油量調節ねじ	1
4		236-29801	LUBRICATION CONNECTOR	給油継手	3
5		RO-0371801-00	RUBBER RING	Oリング	1
6		236-30106	TUBE B	チューブB	0.46
7		400-00344	LUBRICATING INLET CAP	給油口キャップ	1
8		236-29306	PIPE STOPPER A	パイプ止めA	8
9		236-29405	PIPE STOPPER B	パイプ止めB	1
10		RO-0481901-00	RUBBER RING	Oリング	1
11		400-00343	LUBRICATING INLET	給油口	1
12		236-29801	LUBRICATION CONNECTOR	給油継手	2
13		SS-4121615-SP	SCREW 3/16-28 L=16	止めねじ 3/16-28 L=16	1
14		236-30007	TUBE	チューブ	0.07
15		236-30007	TUBE	チューブ	0.16
16		236-29801	LUBRICATION CONNECTOR	給油継手	1
17		236-30007	TUBE	チューブ	0.215
18		236-30007	TUBE	チューブ	0.04
19		236-30106	TUBE B	チューブB	0.035
20		236-29405	PIPE STOPPER B	パイプ止めB	2
21		236-30650	OIL FILTER JOINT ASM.	オイルフィルタージョイント (組)	1
22		236-30601	OIL FILTER JOINT	オイルフィルタージョイント	1
23		236-30007	TUBE	チューブ	0.05
24		A4078-009-000	BAND (SMALL)	束線バンド	1
25		SL-4051091-SC	SCREW M5X0.8 L=10	なべ小ねじセムス M5X0.8 L=10	1
26		WP-0501016-SD	WASHER 5X10.5X1	平座金 5X10.5X1	1
27		SS-4120915-SP	SCREW 3/16-28 L=9	なべねじ 3/16-28 L=9	1
28		236-30007	TUBE	チューブ	0.02
29		402-21270	OIL LEVEL SWITCH CAP	オイルタンク蓋 (上)	1
30		402-21271	O-RING	Oリング	1
31		402-19976	FLOATER_SENSOR	フロートセンサ	1

# 15. THREAD TRIMMER MECHANISM COMPONENTS

糸切り関係

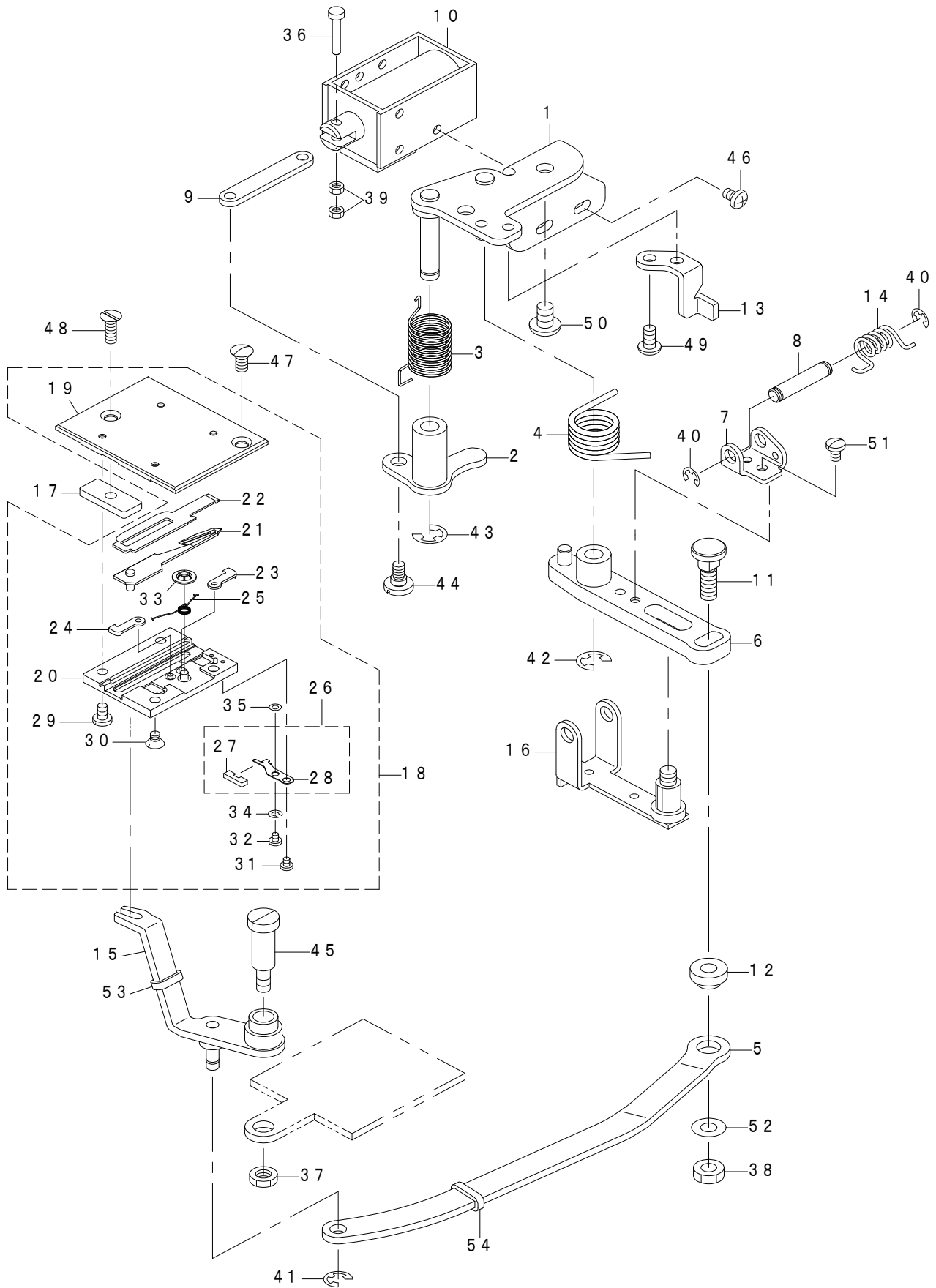

REF.NO	NOTE	PART NO	DESCRIPTION	品名	Qty
1		400-10290	BASE PLATE ASM.	ベース板 (組)	1
2		235-42053	CLUTCH PLATE ASM.	クラッチ板 (組)	1
3		235-42103	CLUTCH RETURN SPRING	クラッチ戻しばね	1
4		235-42202	KNIFE RETURN SPARING	メス戻しばね	1
5		235-41808	MOVING KNIFE LINK	動メスリンク	1
6		110-40854	KNIFE DRIVING ARM ASM.	メス駆動腕 (組)	1
7		229-49002	ROLLER ARM SEAT	コロ腕座	1
8		229-49101	ROLLER FULCRUM SHAFT	コロ支点軸	1
9		225-54505	CLUTCH LINK	クラッチリンク	1
10		402-19990	THREAD_TRIMMER_SOLENOID	糸切ソレノイド	1
11		400-10295	MOVING KNIFE LINK PIN	動メスリンクピン	1
12		225-54802	MOVING KNIFE LINK BASE	動メスリンク座	1
13		225-54901	DRIVING ARM STOPPER	駆動腕ストッパー	1
14		225-55304	ROLLER RETURN SPRING	コロ戻しばね	1
15		225-55551	FORK KNIFE ASM.	メス二又 (組)	1
16		225-55858	ROLLER ARM ASM.	コロ腕 (組)	1
17		225-56906	FIXED PLATE	固定板	1
18		225-57458	KNIFE UNIT	メスユニット	1
19		225-58308	SLIDING PLATE	滑り板	(1)
20		225-58407	KNIFE BASE	メス土台	(1)
21		225-57557	DRIVING KNIFE ASM.	動メス (組)	(1)
22		225-57706	FIXED KNIFE	固定メス	(1)
23		225-57805	KNIFE STOPPER RIGHT	メス掛け板 (右)	(1)
24		225-57904	KNIFE STOPPER LEFT	メス掛け板 (左)	(1)
25		225-58209	SPRING	メス掛けばね	(1)
26		225-58159	CLAMP PLATE ASM.	クランプ板 (組)	(1)
27		225-58001	FELT	クランプフェルト	(1)
28		225-58100	CLAMP PLATE	クランプ板	(1)
29		SS-7090610-SP	SCREW 9/64-40 L=6	丸平ねじ 9/64-40 L=6	(2)
30		SS-1090510-SP	SCREW 9/64-40 L=5	皿ねじ 9/64-40 L=5	(2)
31		SS-7060310-SP	SCREW 3/32-56 L=3	丸平ねじ 3/32-56 L=3	(1)
32		SS-7060310-SP	SCREW 3/32-56 L=3	丸平ねじ 3/32-56 L=3	(1)
33		NP-2103000-00	LOCATING SPRING WASHER	ブッシュナット	(1)
34		WS-0270002-KN	SPRING WASHER M2.6	ばね座金 M2.6	(1)
35		D2056-772-B0B	WASHER B T=0.4	芯紐押えばね座金 T=0.4	(1)
36		235-42418	CLUTCH LINK PIN	クラッチリンクピン	1
37		NS-6150310-SP	NUT 15/64-28	六角ナット 15/64-28	1
38		NS-6150430-SP	NUT 15/64-28	六角ナット 15/64-28	1
39		NM-6030001-SB	NUT M3	六角ナット M3X0.5 1種	2
40		RE-0400000-K0	E-RING 4	E形止め輪 4	2
41		RE-0500000-K0	E-RING	E形止め輪 5	1
42		RE-0600000-K0	E-RING 6	E形止め輪 6	1
43		RE-0600000-K0	E-RING 6	E形止め輪 6	1
44		SD-0600291-TP	HINGE SCKEW D=6 H=2.9	段ねじ D=6 H=2.9	1
45		SD-0791503-SP	HINGE SCREW D=7.94 H=15	段ねじ D=7.94 H=15	1
46		SM-4040601-SC	SCREW M4X0.7 L=6	なべ小ねじ M4X0.7 L=6	3
47		SS-2110920-TP	SCREW 11/64-40 L=8.5	マルサラネジ 11/64-40 L=8.5	1
48		SS-2111010-TP	SCREW 11/64-40 L=9.5	丸皿ねじ 11/64-40 L=9.5	1
49		SS-4110915-SP	SCREW 11/64-40 L=9	なべねじ 11/64-40 L=9	2
50		SS-4150915-SP	SCREW 15/64-28 L=9	なべねじ 15/64-28 L=9	2
51		SS-7090610-SP	SCREW 9/64-40 L=6	丸平小ねじ 9/64-40 L=6	1
52		WP-0621016-SH	WASHER	平座金	1
53		229-19203	OIL PROTECTING RUBBER	天秤油切りゴム	1
54		BP-6000000-00	VINYL PIPE	ビニールパイプ	1

# 16. WIPER COMPONENTS

ワイパー関係

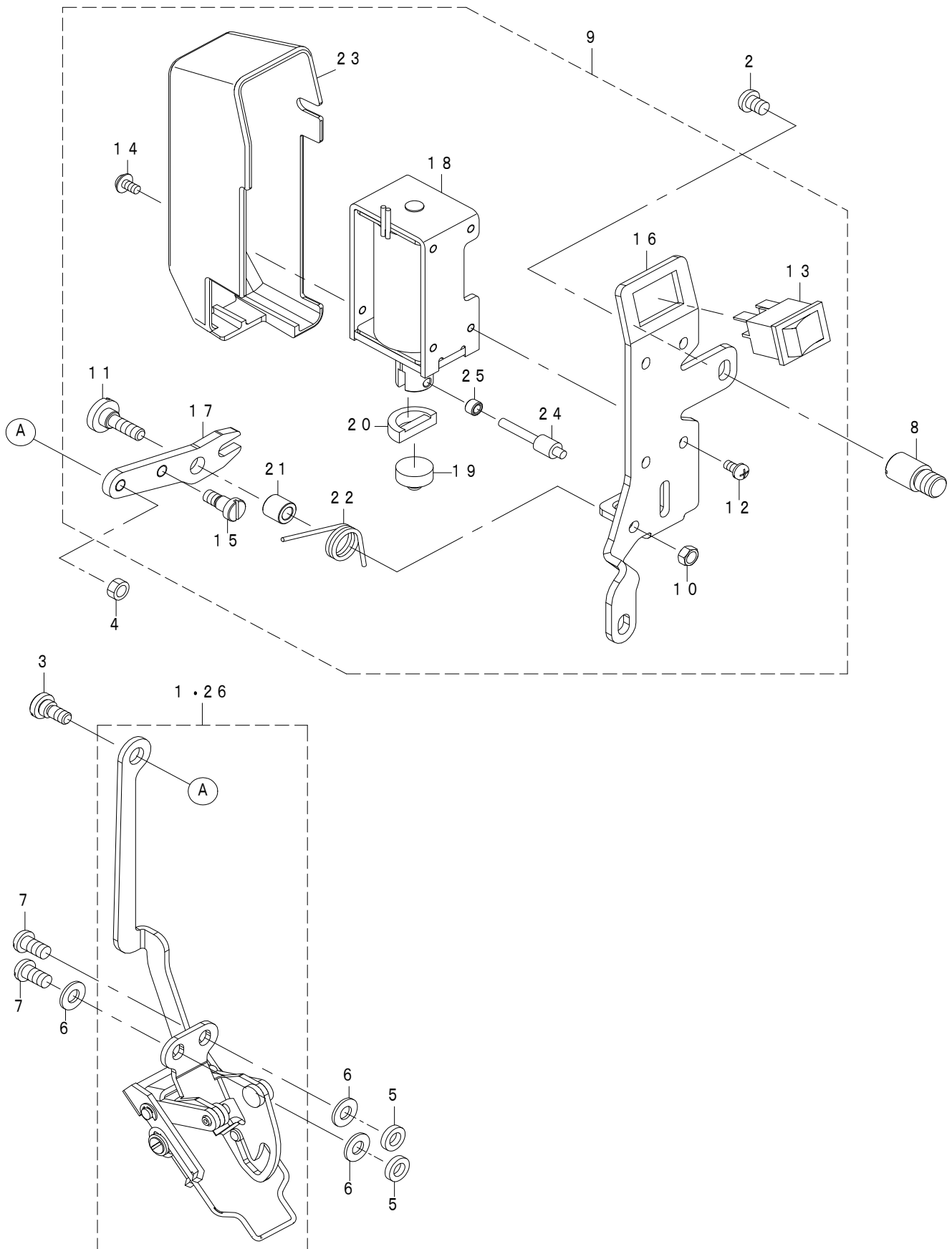

REF.NO	NOTE	PART NO	DESCRIPTION	品 名	Qty
1	#01	402-09350	WIPER_ASM	ワイパー (組)	1
2		SS-4120615-SP	SCREW 3/16-28 L=6	なべねじ 3/16-28 L=6	2
3		SD-0600271-SP	HINGE SCREW D=6 H=2.7	段ねじ D=6 H=2.7	1
4		NS-6110310-SP	HEXAGONAL NUT 11/64-40	六角ナット 11/64-40	1
5		400-21606	WASHER(B)	座金B	1
6		WP-0501016-SD	WASHER 5X10.5X1	平座金 5X10.5X1	3
7		SS-4120915-SP	SCREW 3/16-28 L=9	なべねじ 3/16-28 L=9	2
8		401-25647	STUD	スタッド	1
9		402-09325	WIPER_SOLENOID_ASM	ワイパーソレノイド (組)	1
10		NS-6110310-SP	HEXAGONAL NUT 11/64-40	六角ナット 11/64-40	(1)
11		SD-0650321-TP	SHOULDER SCREW D=6.5 H=3.2	段ねじ D=6.5 H=3.2	(1)
12		SL-4030641-SE	SCREW	座金付きねじ	(4)
13		HA-0060000-0A	SWITCH	スイッチ	(4)
14		SL-4030631-SC	SCREW M3X6	座金付きなべ小ねじ M3 L=6	(1)
15		SD-0500481-TP	HINGE SCREW D=5 H=4.8	段ねじ D=5 H=4.8	(1)
16		401-25645	WIPER_BASE	ワイパー台	(1)
17		225-62201	WIPER LINK	ワイパーリンク A	(1)
18		402-19991	WIPER SOLENOID ASM.	ワイパーソレノイド (組)	(1)
19		229-55900	WIPER RUBBER A	ワイパーゴムA	(1)
20		229-56007	WIPER RUBBER B	ワイパーゴムB	(1)
21		229-56205	WIPER HINGE SCREW COLLAR	ワイパー段ねじカラー	(1)
22		229-56304	WIPER SPRING	ワイパーばね	(1)
23		401-96122	WIPER_COVER	ワイパーカバー	(1)
24		229-57104	WIPER SOLENOID SHAFT	ワイパーソレノイド軸	(1)
25		229-57203	WIPER LINK COLLAR	ワイパーリンクカラー	(1)
26	#01	402-15739	WIPER_ASM	ワイパー (組)	1
		NOTE(注記)	#01...VARIOUS NOS.FOR DESTINATIONS	仕向地により異なる	

# 17. OPERATION PANEL COMPONENTS

操作パネル関係

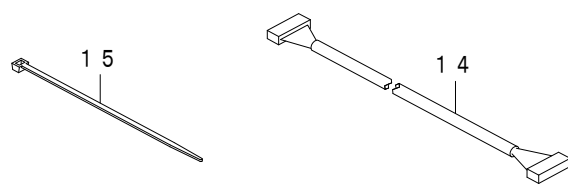
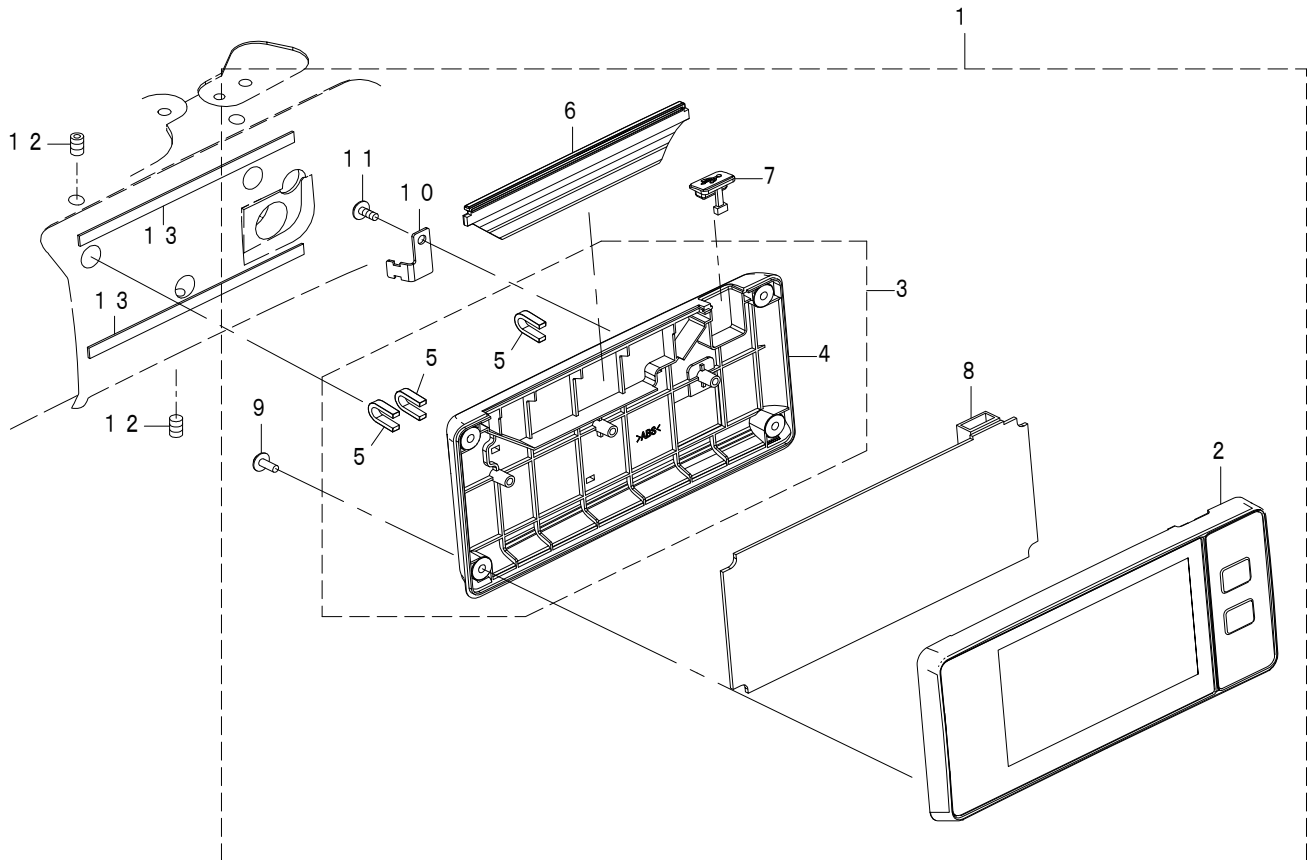

REF.NO	NOTE	PART NO	DESCRIPTION	品 名	Qty
1		402-19970	PANEL-F ASSY FOR LZ2290C	パネルF組 LZ2290C	1
2		401-73451	PANEL_COVER_F ASSY	操作パネルカバー前F組	(1)
3		401-73459	PANEL_COVER_R ASM	操作パネルカバー後組	(1)
4		401-72386	PANEL_COVER_R	操作パネルカバー後	(1)
5		401-72420	FIX_PLATE	U形固定板	(3)
6		401-72422	INDICATOR	インジケータ	(1)
7		401-72423	USB_COVER	USBカバー	(1)
8		401-69398	PNL-F PCB ASSY	パネルF 基板組	(1)
9		SV-4030802-SN	TAPPING SCREW WITH FLANGE M3X8	座付きタッピンねじ	(1)
10		401-74580	PANEL_CABLE_CLAMP_PLATE	パネルケーブル固定板	(1)
11		SV-4030802-SN	TAPPING SCREW WITH FLANGE M3X8	座付きタッピンねじ	(4)
12		SM-8050852-TP	SCREW M5 L=8	止めねじ M5 L=8	3
13		401-74408	PANEL_CSHION_RUBBER	パネルクッションゴム	2
14		401-75585	CTL-PNL CORD ASSY	CTL-PNLコード組	1
15		EA-9500B01-00	CABLE BAND	束線バンド	1

# 18. UNDER COVER COMPONENTS

アンダーカバー関係

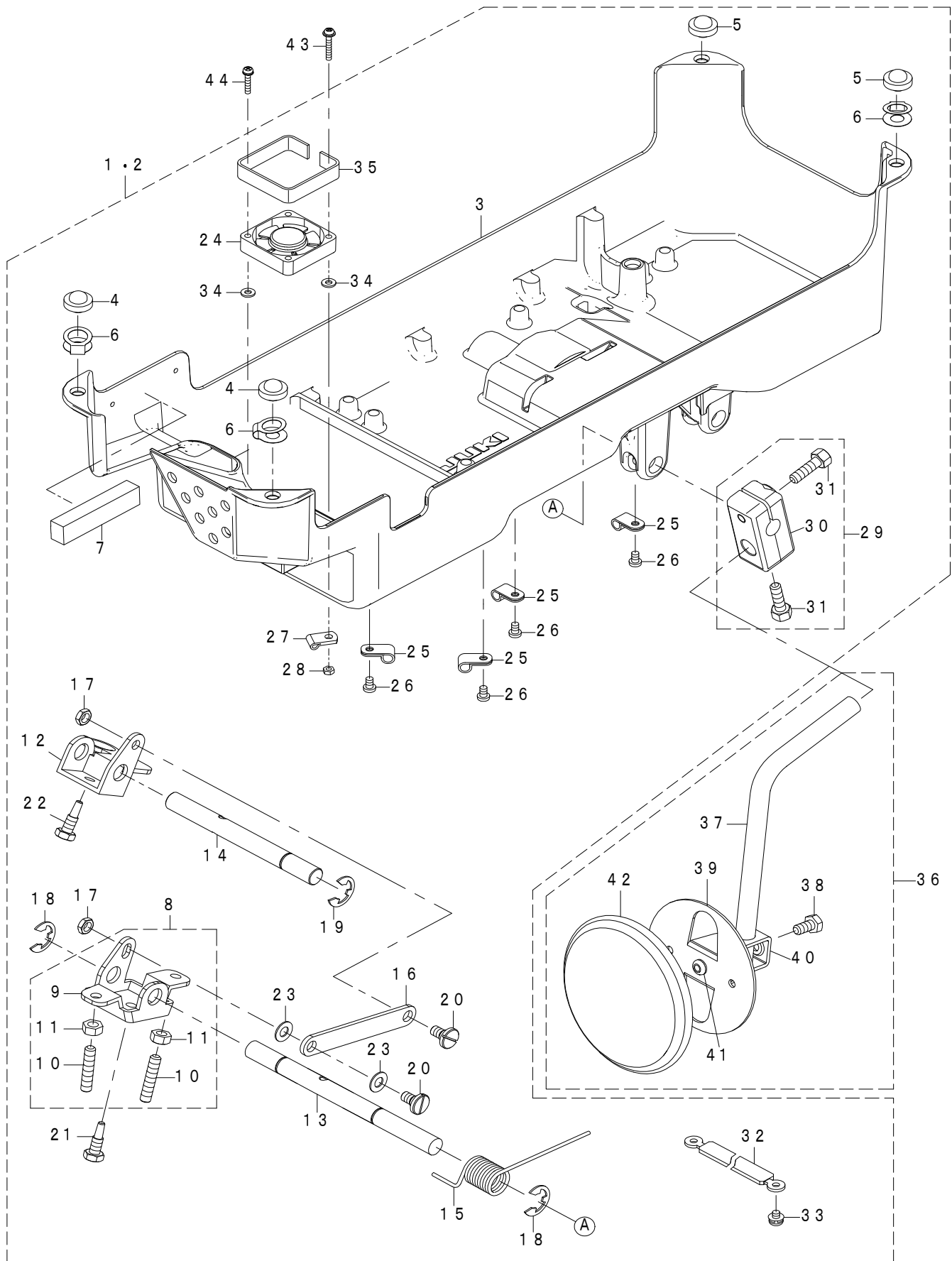



REF.NO	NOTE	PART NO	DESCRIPTION	品名	Qty
1	#01	402-09323	OIL_RESERVOIR_ASM	アンダーカバー組	1
2	#01	402-19946	OIL_RESERVOIR_ASM	アンダーカバー組	1
3		402-09322	OIL_RESERVOIR	アンダーカバー	(1)
4		110-47107	RUBBER CUSHION	頭部支えゴム	(2)
5		101-62600	RUBBER CUSHION	頭部支えゴム	(2)
6	#01	402-18924	CE_BLOCK	CE板	(3)
7	#01	402-19979	CONDUCTIVE GASKET	導電ガスケット	(1)
8		236-39156	BRACKET ASM.	膝上げ回転腕 (組)	(1)
9		236-39107	BRACKET	膝上げ回転腕	(1)
10		SM-8063012-TR	SCREW M6 L=30	止めねじ	(2)
11		NM-6060001-SE	NUT M6	六角ナット M6 1種	(2)
12		236-39206	CONNECTING ROT	膝上げ差動腕	(1)
13		236-39305	KNEE PRESS ROD	膝当て横軸	(1)
14		236-39404	SHAFT	膝上げ差動軸	(1)
15		236-39503	SPRING	膝上げ回転腕ばね	(1)
16		236-39602	CONNECTING ROD	膝上げ連結ロッド	(1)
17		NS-6150310-SP	NUT 15/64-28	六角ナット 15/64-28	(2)
18		RE-1000000-KO	E-RING 10	E形止め輪 10	(2)
19		RE-1000000-KO	E-RING 10	E形止め輪 10	(1)
20		SD-0720331-SP	HINGE SCREW D=7.24 H=3.3	段ねじ D=7.24 H=3.3	(2)
21		SM-9061853-SR	SCREW M6 L=17.5	六角ボルト	(1)
22		SM-9061853-SR	SCREW M6 L=17.5	六角ボルト	(1)
23		WP-0650876-SD	WASHER 6.5X13X0.8	平座金 6.5X13X0.8	(2)
24		401-91349	FAN MOTOR ASSY	ファンモータ組	(1)
25		HX-0015000-0A	CABLE CLAMP	ケーブルクリップ	(4)
26		SM-4040601-SC	SCREW M4X0.7 L=6	なべ小ねじ M4X0.7 L=6	(4)
27		HX-0015000-00	CLIP	ケーブルクリップ	(1)
28		NM-6030001-SN	NUT	六角ナット	(1)
29		229-32453	BRACKET ASM.	膝当て立軸取付腕 (組)	(1)
30		229-32404	BRACKET	膝当て立軸取付腕	(1)
31		SM-9062053-SR	SCREW M6 L=20	六角ボルト	(2)
32	#01	402-19977	GROUNDING WIRE 150	アンダーカバーグラウンド線 150	(2)
33	#01	SL-4040681-SC	SCREW M4 L=6	座金付きなべ小ねじ M4 L=6	(2)
34		WP-0371016-SD	WASHER 3.7X8X1	平座金 3.7X8X1	(4)
35		402-19999	SPACER	スペーサ	(1)
36		229-34251	KNEE PAD PLATE ASM.	膝当て板 (組)	1
37		229-34608	KNEE PAD UPRIGHT SHAFT	膝当て立軸	(1)
38		SM-9061203-SE	SCREW M6 L=12	六角ボルト M6 L=12	(1)
39		229-34202	KNEE PAD PLATE	膝当て板	(1)
40		229-34301	KNEE PAD PLATE SUPPORT	膝当て板支え	(1)
41		229-34400	KNEE PAD PLATE RUBBER	膝当て板ゴム	(1)
42		229-34509	KNEE PAD PLATE COVER	膝当て板カバー	(1)
43		SL-4032091-SC	SCREW	止めねじ	1
44		SL-4031681-SC	SCREW M3 X 16	なべ小ねじセムス M3 L=16	3
		NOTE(注記)	#01....VARIOUS NOS.FOR DESTINATIONS	仕向地により異なる	

# 19. THREAD STAND COMPONENTS

糸立装置関係

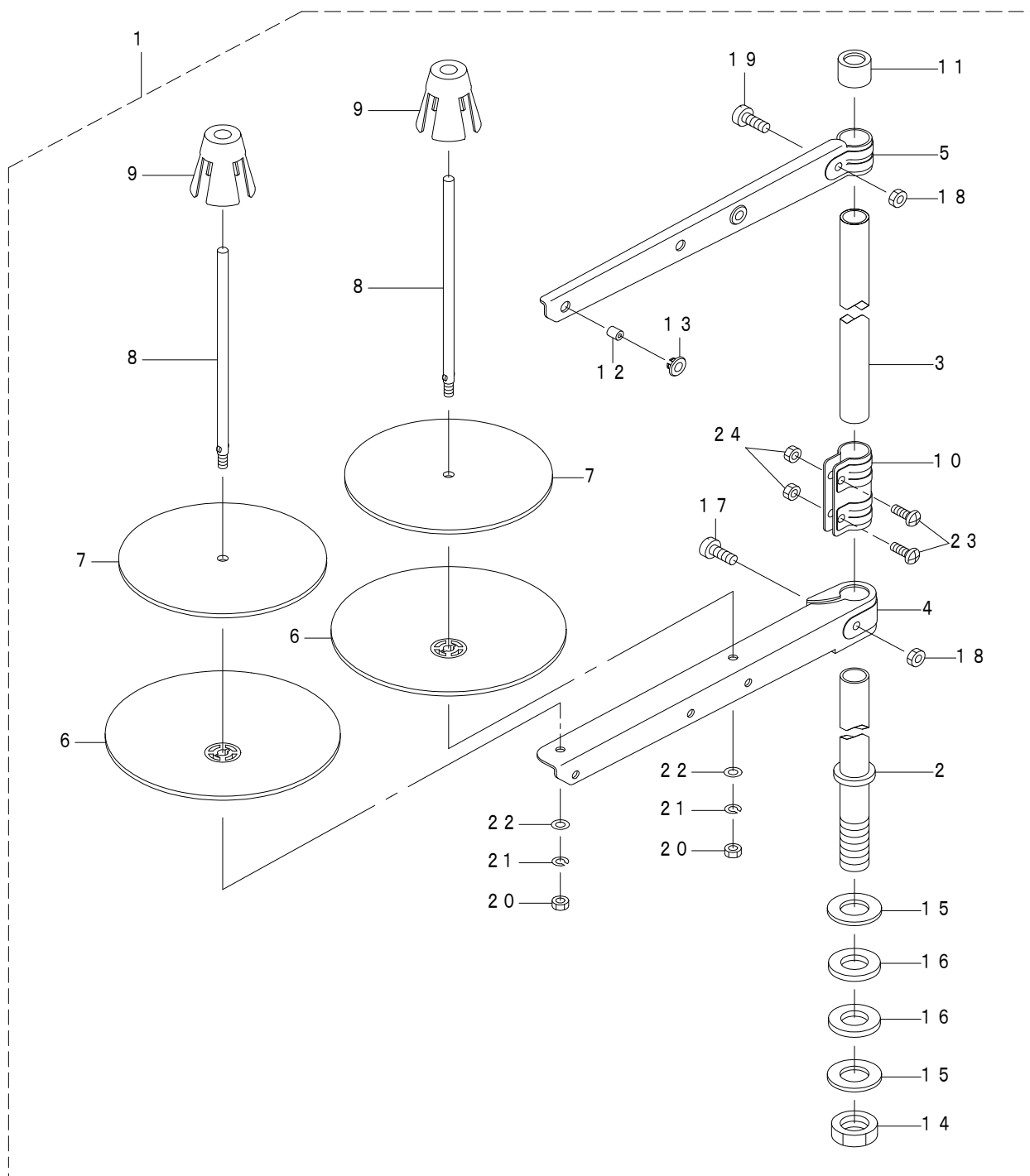

REF.NO	NOTE	PART NO	DESCRIPTION	品名	Qty
1		400-96354	THREAD STAND ASM.	糸立装置 (組)	1
2		400-85784	SPOOL REST ROD (LOWER)	糸立棒 (下)	(1)
3		400-85785	SPOOL REST ROD (UPPER)	糸立棒 (上)	(1)
4		400-85786	SPOOL REST ARM (LOWER)	糸立腕 (下)	(1)
5		400-85787	SPOOL REST ARM (UPPER)	糸立腕 (上)	(1)
6		400-85788	SPOOL REST	糸巻受皿	(2)
7		400-85789	SPOOL REST CUSHION	糸巻受皿クッション	(2)
8		400-85790	SPOOL PIN	糸巻受棒	(2)
9		400-85791	SPOOL RETAINER	糸巻振れ止め	(2)
10		400-85792	SPOOL REST ROD JOINT	糸立棒継手	(1)
11		400-85793	SPOOL REST ROD RUBBER CAP	糸立棒保護キャップ	(1)
12		400-85794	THREAD GUIDE	糸道	(2)
13		400-85795	THREAD GUIDE BUSHING	糸道ブッシュ	(2)
14		400-96325	SPOOL REST ROD NUT	糸立棒止めナット	(1)
15		WP-1612616-SE	WASHER 16X30X2.6	平座金	(2)
16		400-85796	SPOOL REST ROD RUBBER CUSHION	糸立棒防振ゴム	(2)
17		400-96326	SPOOL REST ARM LOWER SCREW	糸立腕 (下) 止めねじ	(1)
18		NM-6050001-SE	NUT M5	六角ナット M5	(2)
19		400-96327	SPOOL REST ARM UPPER SCREW	糸立腕 (上) 止めねじ	(1)
20		NM-6050001-SE	NUT M5	六角ナット M5	(2)
21		WS-0510002-KN	SPRING WASHER M5	ばね座金 M5	(2)
22		WP-0531001-SC	WASHER M5	平座金みがき丸 M5	(2)
23		SM-4051405-SE	SCREW M5 L=14	なべ小ねじ M5 L=14	(2)
24		NM-6050001-SE	NUT M5	六角ナット M5	(2)

## 20. ACCESSORIE PARTS COMPONENTS

付属品関係

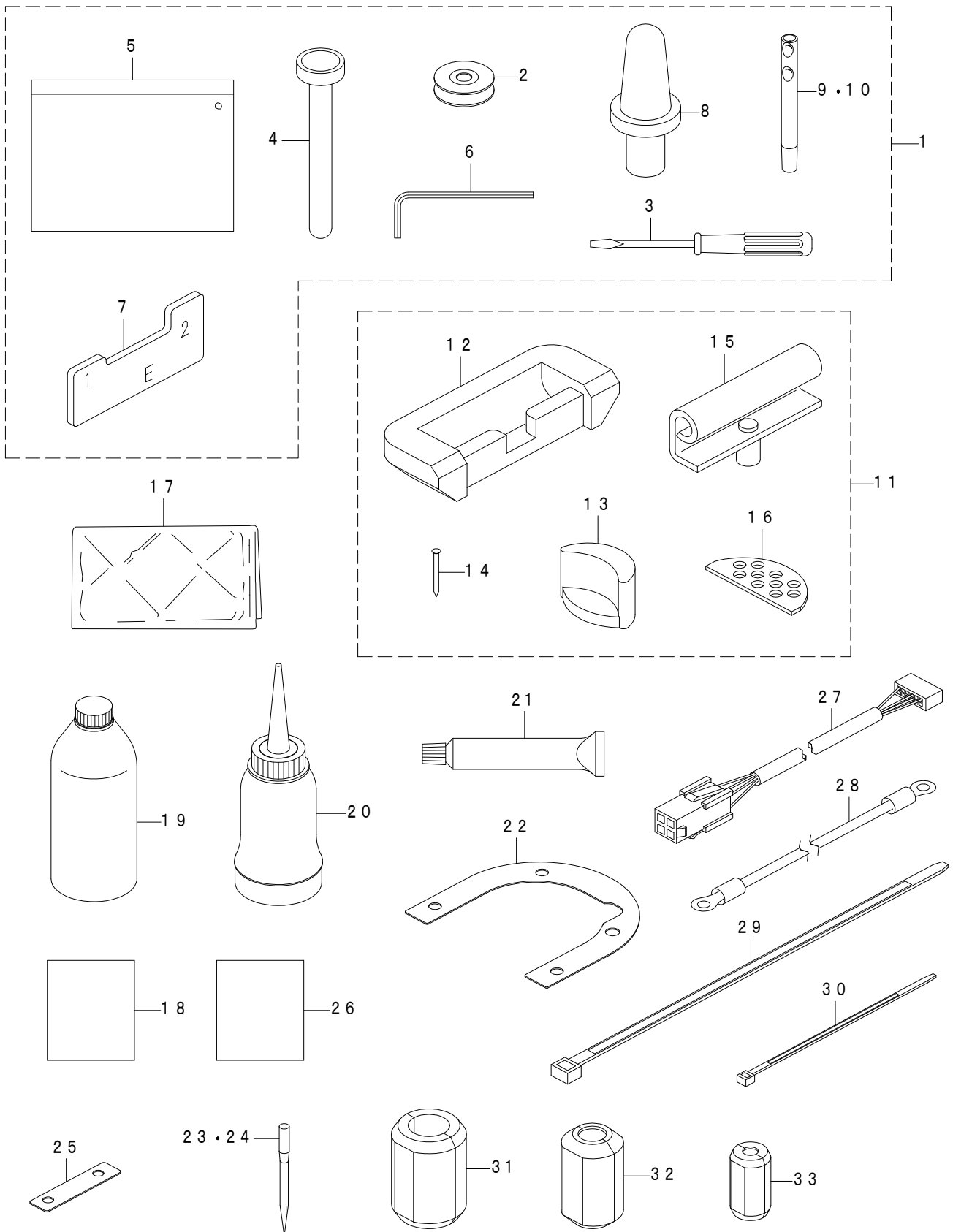

REF.NO	NOTE	PART NO	DESCRIPTION	品名	Qty
1		402-15736	ACCESSORIE_BAG_ASM.	付属品バッグ組	1
2		225-96704	BOBBIN S	ボビン S	(1)
3		229-33204	SCREW DRIVER SMALL	ドライバー (小)	(1)
4		236-39701	KNEE LIFTER PRESSER ROD	膝上げ押し棒	(1)
5		229-32800	ACCESSORIE BAG	付属品バッグ	(1)
6		B9102-057-000	WRENCH (3/32)	六角棒スパナ 3/32	(1)
7		225-36502	TIMING GAUGE E	タイミングゲージE	(1)
8		401-74570	HEAD_SUPPORT_ROD	頭部支え棒	(1)
9	#03	229-58300	NEEDLE THREAD GUIDE PIN	糸案内棒	(1)
10	#01	225-02504	THREAD GUIDE BAR	糸案内棒	(1)
11		229-58052	RUBBER HINGE ASM.	ラバーひんじ (組)	1
12		229-26000	RUBBER CUSHION	ゴムひんじ座	(2)
13		229-58003	FRAME RUBBER CUSHION	頭部支えゴム座	(2)
14		229-26208	NAIL	止め釘	(8)
15		229-26356	HINGE COMPL.	ひんじ結合	(2)
16		229-26505	WASHER	頭部クッション座	(2)
17		262-34005	VINYL COVER	頭部ビニールカバー	1
18		293-42409	SHEET	LZ2290セットアップ注意シート	1
19		MDF-RX1200C0	NEW DEFRIX OIL NO.1 (200ML)	デフレックスオイルNO. 1 (200ML)	1
20		B9121-012-0A0	OILER ASM.	油差し (組)	1
21		400-06323	JUKI GREASE A TUBE	ジューキグリースAチューブ	1
22	#01	225-03908	SPACER	針板スペーサー	1
23	#02	MC-1923007-52	NEEDLE 438 #75-2	針 (シュメッツ) 438 #75-2	1
24	#02	MDP-500B1002	NEEDLE DPX5 #10-2	針 DPX5 #10-2	1
25	#01	100-25906	SPACER	送り台スペーサ	1
26	* #04	402-50030	DECLARATION_OF_INCORPORATION	組込宣言書	1
27	*	402-40053	SENSOR RELAY CABLE A ASSY	センサ中継ケーブルA組	1
28	*	402-40056	SENSOR EARTH CORD ASM	センサーアースコード組	1
29	*	HX-0006500-0B	CABLE BAND	ソクセンバンド	2
30	*	EA-9500B01-00	CABLE BAND	ソクセンバンド	7
31	* #04	HN-0021100-00	CORES	コア	2
32	* #04	HN-0028400-00	CORES	コア	1
33	* #04	HN-0047200-00	CORES	コア	1
		NOTE(注記)	#01....FOR LZ-2290CS-7/LZ-2290CF	LZ-2290CS-7/LZ-2290CF用	
			#02....VARIOUS NOS.FOR DESTINATIONS	仕向地により異なる	
			#03....FOR LZ-2290CS-0B	LZ-2290CS-0B用	
			#04....TYPE BB	BB仕様	

## 21. SPECIAL ORDER PARTS

特別注文部品

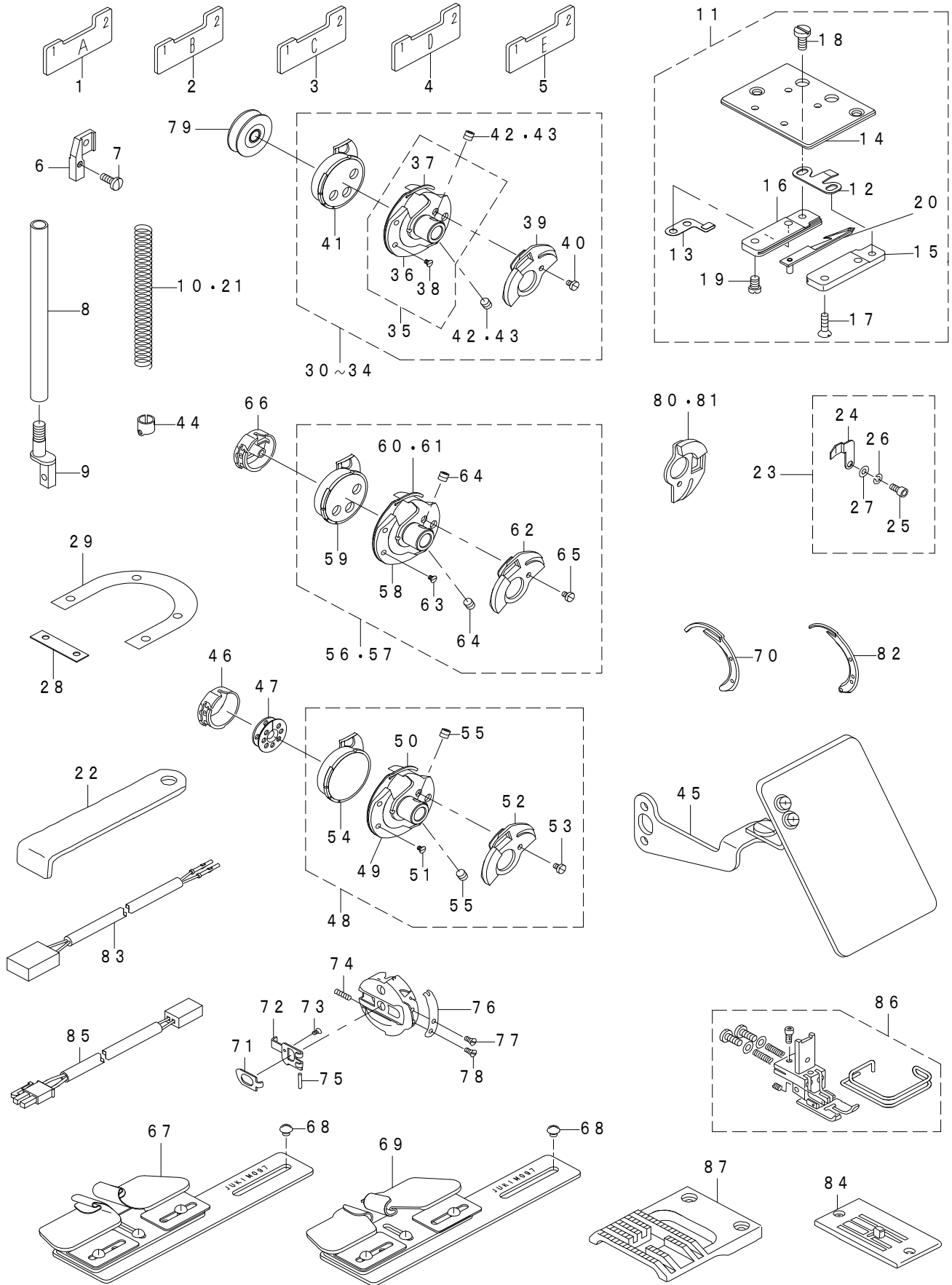

REF.NO	NOTE	PART NO	DESCRIPTION	品名	Qty
1		225-35801	TIMING GAUGE	タイミングゲージ	1
2		225-86705	TIMING GAUGE	タイミングゲージ	1
3		225-35900	TIMMING GAUGE RIGHT	タイミングゲージR	1
4		225-36403	TIMMING GAUG D	タイミングゲージD	1
5		225-36502	TIMING GAUGE E	タイミングゲージE	1
6		B1551-586-000	PRESSER FOOT JOINT	押え連結足	1
7		SS-7090910-SP	SCREW 9/64-40 L=8.5	丸平ねじ 9/64-40 L=8.5	1
8		D1501-583-H00	PRESSER BAR	押え棒	1
9		D1502-583-H00	PRESSER BAR	押え棒継足	1
10		B1505-227-T00-A	PRESSER SPRING	押え調節ばね	1
11		225-56054	KNIFE UNIT	メスユニット	1
12		225-56302	FIXED KNIFE	固定メス	(1)
13		225-56450	CLAMP PLATE ASM.	クランプ板(組)	(1)
14		225-56609	SLIDING PLATE	滑り板	(1)
15		225-56708	DRIVING BASE	動メス台_左	(1)
16		225-56807	DRIVING BASE	動メス台_右	(1)
17		SS-1090510-SP	SCREW 9/64-40 L=5	皿ねじ 9/64-40 L=5	(2)
18		SS-6090420-SP	SCREW 9/64-40 L=4.0	平ねじ 9/64-40 L=4	(2)
19		SS-7090710-SP	SCREW 9/64-40 L=6.8	丸平ねじ 9/64-40 L=6.8	(2)
20		225-56153	DRIVING KNIFE ASM.	動メス(組)	(1)
21		111-62104	SPRING	押え調節ばね	1
22		B9101-490-000	DRIVER	ドライバ	1
23		225-25455	NEEDLE HOLDER ASM.	針曲がり対応針受(組)	1
24		225-25406	NEEDLE GUARD	針曲がり対応針受	(1)
25		SM-6030602-TP	SCREW M3X0.5 L=6	六角穴ボルト M3X0.5 L=6	(1)
26		WS-0310702-KS	SPRING WASHER	ばね座金 3.1X5.9X0.7	(1)
27		WP-0320500-SC	WASHER M3	平座金小形丸 M3	(2)
28		100-25906	SPACER	送り台スベーサ	1
29		225-03908	SPACER	針板スベーサー	1
30		225-25059	HOOK COMPL.	カマケツゴウ R	1
31		225-26677	HOOK COMPL. V(PLASTIC HOOK)	釜結合 V (プラスチック釜)	1
32		225-26578	HOOK COMPL. V(HARD POINT)	釜結合 V (ハードポイント)	1
33		225-25257	HOOK COMBINATION (HARD POINT)	釜結合 (ハードポイント)	1
34		225-25752	HOOK ASM. (PLASTIC)	釜結合 (プラスチック釜)	1
35		225-25968	ROTATING HOOK V ASM.	外釜 V (組)	(1)
36		225-25919	OUTER HOOK V	外釜 V	(1)
37		235-03501	INNER HOOK PRESSER V-S	内釜押え V-S	(1)
38		100-33009	HOOK GIB SCREW	内釜押え止めねじ	(2)
39		225-26206	REVERSE PLATE V	裏板 V	(1)
40		100-33108	HOOK COUNTER BALANCE SCREW	裏板止めねじ	(1)
41		225-26008	INNER HOOK V	内釜 V	(1)
42		SS-8110422-TP	SCREW 11/64-40 L=4	止めねじ 11/64-40 L=4	(2)
43		SS-8110520-TP	SCREW 11/64-40 L=4.5	止めねじ 11/64-40 L=4.5	(2)
44		225-07701	THRED RACK RIGHT	針棒糸掛け R	1
45		225-03353	SAFETY PLATE ASM.	安全プレート(結合)	1
46		235-22550	NOT TURN BOBBIN CASE ASM.	無回転ボビンケース(組)	1
47		235-23004	NOT TURN BOBBIN	無回転ボビン	1
48		235-23152	NOT TURN BOBBIN HOOK COMPL. V	無回転ボビン釜結合 V	1
49		225-25919	OUTER HOOK V	外釜 V	(1)
50		235-03501	INNER HOOK PRESSER V-S	内釜押え V-S	(1)
51		100-33009	HOOK GIB SCREW	内釜押え止めねじ	(2)
52		235-23202	NOT TURN BOBBIN INNER HOOK V	無回転ボビン内釜 V	(1)
53		100-33108	HOOK COUNTER BALANCE SCREW	裏板止めねじ	(1)
54		225-26008	INNER HOOK V	内釜 V	(1)
55		SS-8110422-TP	SCREW 11/64-40 L=4	止めねじ 11/64-40 L=4	(2)
56	#01	235-03659	HOOK COMPL. S	釜結合 S	1
57	#02	235-02958	HOOK CONNECTION K	釜結合 K	1
58		235-03709	OUTER HOOK S	外釜 S	(1)
59		235-03808	INNER HOOK S	内釜 S	(1)
60	#01	235-03907	INNER HOOK PRESSER S	内釜押え S	(1)
61	#02	235-03006	INNER HOOK PRESSER K	中釜押え K	(1)
62		235-04004	BACK PLATE S	裏板 S	(1)
63		235-04103	INNER HOOK PRESSER SETSCREW S	内釜押え止めねじ S	(3)
64		235-04301	OUTER HOOK SETSCREW S	外釜止めねじ S	(2)
65		235-04400	HOOK COUNTER BALANCE SCREW S	裏金止めねじ S	(1)
66		235-04657	BOBBIN CASE WITH SPRING	ボビンケース S 空転防止ばね入り	1
67	#03	MAM-09700BA0	FAGOTING FOLDER ASM.	ファゴット上巻きホルダー(組)	1
68	#03	SS-5110710-SP	SCREW 11/64-40 L=7	トラスねじ 11/64-40 L=7	2
69	#03	MAM-097000A0	FAGOTTING FELLER	ファゴット縫いホルダー(組)	1
70		400-16408	HOOK GIB VS	フックギブ	1
71		198-00903	LC-601-1/ LATCH LEVER	LC-601-1-1/ラッチレバー	1
72		198-01000	LC-602-2/ LATCH	LC-602-2-2/ラッチ	1
73		198-01307	SMS-801-B/ SETSCREW PICK-UP	SMS-801-B/止めねじつまみ	1
74		198-01109	LSP-4/ LATCH SPRING	LSP-4/ラッチスプリング	1
75		198-01208	LFP-1/ LATCH PIN	LFP-1/ラッチピン	1
76		198-01406	TSP-604-B/ TENSION SPRING	TSP-604-B/調子ばね	1
77		198-01505	SMS-608-B/ TENSION SCREW	SMS-608-B/調子ねじ	1
78		198-01604	SMS-609-B/ SETSCREW TENSION SPRING	SMS-609-B/止めねじ調子ばね	1
79		225-24201	BOBBIN	ボビン	1
80		225-24805	REVERSE PLATE	裏板	1
81		225-26206	REVERSE PLATE V	裏板 V	1
82		235-03303	INNER PRESSER V-S4	内釜押え V-S4	1
83		400-08168	OP SWITCH CABLE A ASM.	OPスイッチケーブルA(組)	1
84	#03	100-61554	THROAT PLATE ASM.	針板(組)	1
85		400-91888	FAN RELAY CABLE	ファン中継コード(LZ用)	1
86	#03	225-91564	PRESSER FOOT ASM.	押え(組)	1
87	#03	100-64004	FEED DOG	送り歯	1
		NOTE(注記)	#01....FOR INNER HOOK S #02....FOR INNER HOOK K #03....VARIOUS NOS.FOR DESTINATIONS	内釜 S 用 内釜 K 用 仕向地により異なる	

**22. LIST FOR INFORMATION OF CHANGE**

**変更情報リスト**

As to the place changed, refer to the corresponding Rev. No.  
When previous parts (Obsolete part) and new parts (Added parts) are  
not interchangeable with each other:

In this case, even obsoleted parts (D.) can be ordered with the  
obsoleted part number, so select the parts with changed dates and  
place your orders.

変更箇所は、該当Rev. No. 版をご参照ください。

部品の互換性がない変更の場合は、削除された品番でも、ご注文できます。

No. 1731-02...Rev. No.

\*A: Added parts追加部品 / D: Obsoleted parts削除部品 / E: Erratum訂正

* D	Rev. No.	Page 頁	Ref. No.	Parts No. 品 番	* A	Rev. No.	Page 頁	Ref. No.	Parts No. 品 番
	01	22	7	401-74313					
					A	02	22	7	402-54811
					A	02	40	26	402-50030
					A	02	40	27	402-40053
					A	02	40	28	402-40056
					A	02	40	29	HX-0006500-0B
					A	02	40	30	EA-9500B01-00
					A	02	40	31	HN-0021100-00
					A	02	40	32	HN-0284000-00
					A	02	40	33	HN-0047200-00



NUMERICAL INDEX OF PARTS

索引

PART NO 品番	PAGE 頁	REF NO	PART NO 品番	PAGE 頁	REF NO	PART NO 品番	PAGE 頁	REF NO	PART NO 品番	PAGE 頁	REF NO
A4078-009-000	28	24	NS-6110310-SP	32	10	SM-4040601-SC	36	26	SS-4080620-TP	16	66
			NS-6150310-SP	30	37	SM-4040655-SP	2	7	SS-4110615-SP	16	27
BP-6000000-00	30	54	NS-6150310-SP	36	17	SM-4040655-SP	4	46	SS-4110915-SP	2	34
B1307-155-0A0	18	18	NS-6150430-SP	30	38	SM-4040655-SP	16	4	SS-4110915-SP	8	26
B1308-155-000	18	17	NS-6680410-SP	16	59	SM-4040655-SP	16	15	SS-4110915-SP	8	28
B1505-227-T00-A	42	10				SM-4041455-SN	12	27	SS-4110915-SP	16	24
B1521-555-000	12	12	PS-0400222-K0	8	47	SM-4041455-SN	14	29	SS-4110915-SP	18	24
B1551-586-000	42	6	PS-0800202-KH	2	13	SM-4050655-SP	4	17	SS-4110915-SP	30	49
B1608-555-0A0	16	51				SM-4051055-SP	2	3	SS-4120615-SP	2	36
B2508-704-000	20	21	RC-0410415-KP	22	3	SM-4051055-SP	4	44	SS-4120615-SP	32	2
B3118-552-I00	22	2	RC-1700001-KP	22	13	SM-4051055-SP	22	29	SS-4120915-SP	2	20
B3121-352-000	24	8	RE-0300000-K0	16	76	SM-4051055-SP	24	20	SS-4120915-SP	4	6
B3132-012-000	22	15	RE-0400000-K0	22	23	SM-4051255-SP	10	8	SS-4120915-SP	4	19
B3214-047-000	6	29	RE-0400000-K0	30	40	SM-4051405-SE	38	23	SS-4120915-SP	28	27
B8228-125-000	4	26	RE-0500000-K0	6	19	SM-4051655-SP	16	39	SS-4120915-SP	32	7
B9101-490-000	42	22	RE-0500000-K0	12	33	SM-5040655-SN	6	20	SS-4121215-SP	4	25
B9102-057-000	40	6	RE-0500000-K0	14	30	SM-6030602-TP	42	25	SS-4121615-SP	28	13
B9121-012-0A0	40	20	RE-0500000-K0	22	28	SM-6031002-TN	22	6	SS-4150915-SP	30	50
			RE-0500000-K0	24	25	SM-6040602-TP	16	91	SS-5110710-SP	42	68
CM-3002000-01	2	41	RE-0500000-K0	30	41	SM-6040860-TP	24	19	SS-6060210-SP	4	12
CM-3002000-01	4	13	RE-0600000-K0	30	42	SM-6041002-TP	10	4	SS-6090420-SP	42	18
CM-3002000-03	4	49	RE-0600000-K0	30	43	SM-6041002-TP	14	36	SS-6090540-SP	2	21
CM-3003000-01	16	89	RE-0800000-K0	14	31	SM-6041002-TP	16	36	SS-6110710-TP	26	4
CM-3003000-03	16	37	RE-1000000-K0	36	18	SM-6041202-TP	12	37	SS-6121610-TP	16	67
CM-6001001-01	4	38	RE-1000000-K0	36	19	SM-6041602-TP	16	80	SS-6580752-TP	2	22
CS-1000881-TP	20	18	RO-0360802-00	18	22	SM-6051002-TP	16	34	SS-6580752-TP	16	48
CS-1470710-SH	16	20	RO-0371801-00	8	50	SM-6051400-SP	12	21	SS-6660710-TP	20	13
			RO-0371801-00	12	47	SM-6051400-SP	14	23	SS-6660710-TP	20	19
D1501-583-H00	42	8	RO-0371801-00	28	5	SM-6051602-TP	16	11	SS-7060310-SP	8	38
D1502-583-H00	42	9	RO-0481901-00	18	23	SM-6051850-TP	16	13	SS-7060310-SP	30	31
D2056-772-B0B	30	35	RO-0481901-00	28	10	SM-6061002-TP	2	5	SS-7060310-SP	30	32
			RO-0681901-00	18	35	SM-6061002-TP	10	24	SS-7080410-SP	2	32
EA-9500B01-00	2	42	RO-0781901-00	16	84	SM-6061002-TP	16	33	SS-7080520-SP	8	36
EA-9500B01-00	8	63	RO-0801502-00	2	12	SM-6061002-TP	16	81	SS-7090410-SP	4	24
EA-9500B01-00	12	16	RO-1182401-00	24	12	SM-7040800-SL	22	26	SS-7090610-SP	30	29
EA-9500B01-00	34	15	RO-1721801-00	18	7	SM-7040800-SL	24	23	SS-7090610-SP	30	51
EA-9500B01-00	40	30				SM-8040412-TP	6	21	SS-7090710-SP	42	19
			SB-1060004-00	14	18	SM-8040612-TP	22	4	SS-7090910-SP	42	7
GPK-26023000	10	6	SB-1060005-00	14	5	SM-8050402-TP	16	64	SS-7090910-TP	8	34
GPR-01015000	2	14	SB-1080002-00	14	8	SM-8050502-TP	6	22	SS-7090910-TP	12	23
G1615-880-000	20	11	SB-1080019-00	8	31	SM-8050502-TP	16	86	SS-7090910-TP	14	1
G1615-880-000	20	22	SB-1200008-C0	8	61	SM-80506A2-TP	20	23	SS-7110740-TP	10	15
			SB-1200013-C0	8	14	SM-80506A2-TP	22	16	SS-7110740-TP	16	77
HA-0060000-0A	32	13	SB-3100010-C0	20	12	SM-80506A2-TP	24	13	SS-7111810-TP	16	30
HN-0021100-00	40	31	SB-3220002-CA	16	54	SM-8050612-TP	10	9	SS-7121410-TP	10	18
HN-0028400-00	40	32	SB-3220002-CB	16	55	SM-8050612-TP	16	2	SS-7121410-TP	16	74
HN-0047200-00	40	33	SB-3220002-CC	16	56	SM-8050612-TP	16	45	SS-7681650-TP	8	4
HX-0006500-0B	40	29	SB-3220002-CD	16	57	SM-8050612-TP	16	46	SS-8090670-SP	10	16
HX-0015000-0A	36	25	SB-3220002-CE	16	58	SM-80508A2-TP	12	39	SS-8090670-SP	24	11
HX-0015000-0L	4	5	SD-0500481-TP	32	15	SM-80508A2-TP	14	10	SS-8110410-TP	14	25
HX-0015000-0L	4	43	SD-0600271-SP	32	3	SM-8050852-TP	34	12	SS-8110422-TP	26	6
HX-0015000-00	36	27	SD-0600291-TP	30	44	SM-8051002-TP	26	5	SS-8110422-TP	42	42
			SD-0630275-SP	12	31	SM-80608A2-TP	8	8	SS-8110422-TP	42	55
MAM-09700BA0	42	67	SD-0640751-SP	2	38	SM-80608A2-TP	8	11	SS-8110520-TP	18	25
MAM-097000A0	42	69	SD-0650321-TP	32	11	SM-80608A2-TP	12	8	SS-8110520-TP	42	43
MC-1923007-52	40	23	SD-0720331-SP	36	20	SM-80608A2-TP	14	12	SS-8110750-SP	20	14
MC-2005F07-00	8	39	SD-0791503-SP	30	45	SM-8060812-TP	8	22	SS-8111251-SP	18	8
MDF-RX1200C0	40	19	SD-0900701-TP	16	65	SM-8060812-TP	8	24	SS-8120740-SP	8	48
MDP-500B1000	8	40	SL-4030631-SC	32	14	SM-8060812-TP	20	16	SS-8151230-SP	8	52
MDP-500B1002	40	24	SL-4030641-SE	32	12	SM-8061212-TP	8	58	SS-8660610-TP	8	3
			SL-4031681-SC	36	44	SM-8063012-TR	36	10	SS-8660810-TP	16	68
NM-6030001-SB	30	39	SL-4032091-SC	36	43	SM-9061203-SE	36	38	SS-8660810-TP	18	19
NM-6030001-SN	36	28	SL-4040681-SC	36	33	SM-9061853-SR	36	21	SS-8660810-TP	18	26
NM-6040000-SN	16	83	SL-4040881-SC	2	25	SM-9061853-SR	36	22	SS-8660810-TP	18	27
NM-6040000-SN	22	21	SL-4040881-SC	4	41	SM-9062053-SR	36	31	SS-8660810-TP	20	15
NM-6050001-SE	38	18	SL-4051091-SC	4	23	SS-1090510-SP	30	30	SS-8680730-SP	8	5
NM-6050001-SE	38	20	SL-4051091-SC	28	25	SS-1090510-SP	42	17	ST-4030651-SN	6	23
NM-6050001-SE	38	24	SL-6051492-TN	2	9	SS-1090930-SP	8	15	ST-4040821-SS	4	28
NM-6060001-SC	8	60	SL-6052092-TN	8	19	SS-1110840-SP	2	30	SV-4030802-SN	34	9
NM-6060001-SE	36	11	SL-6061292-TN	12	40	SS-1110840-SP	4	37	SV-4030802-SN	34	11
NM-6060003-SE	12	43	SL-6061292-TN	14	37	SS-2090710-TP	2	29			
NP-2103000-00	30	33	SM-0050801-SC	4	42	SS-2090810-SP	4	8	TA-0180401-M0	18	32
NS-6090310-SP	2	27	SM-0050801-SC	6	24	SS-2090810-SP	4	15	TA-0850604-R0	18	9
NS-6110310-SP	6	28	SM-0050801-SC	6	33	SS-2110920-TP	30	47	TA-1250406-R0	2	15
NS-6110310-SP	32	4	SM-4040601-SC	30	46	SS-2111010-TP	30	48	TA-1250705-R0	2	43

NUMERICAL INDEX OF PARTS

索引

PART NO 品番	PAGE 頁	REF NO	PART NO 品番	PAGE 頁	REF NO	PART NO 品番	PAGE 頁	REF NO	PART NO 品番	PAGE 頁	REF NO
TA-1600406-R0	4	45	225-25257	42	33	229-19203	30	53	235-42053	30	2
			225-25406	42	24	229-20409	24	16	235-42103	30	3
WP-0320500-SC	42	27	225-25455	42	23	229-21407	24	9	235-42202	30	4
WP-0330500-0E	2	16	225-25752	42	34	229-26000	40	12	235-42418	30	36
WP-0371016-SD	36	34	225-25877	18	10	229-26208	40	14	235-44901	8	54
WP-0410516-SD	16	92	225-25919	42	36	229-26356	40	15	235-47557	24	2
WP-0410846-SC	22	27	225-25919	42	49	229-26505	40	16	236-01305	2	10
WP-0410846-SC	24	24	225-25968	42	35	229-32404	36	30	236-04200	8	20
WP-0460556-SD	16	31	225-26008	42	41	229-32453	36	29	236-04200	8	21
WP-0480856-SP	16	75	225-26008	42	54	229-32800	40	5	236-09209	12	13
WP-0482016-SZ	10	3	225-26206	42	39	229-33204	40	3	236-16709	16	19
WP-0501016-SD	28	26	225-26206	42	81	229-34202	36	39	236-26005	24	10
WP-0501016-SD	32	6	225-26578	42	32	229-34251	36	36	236-28803	18	12
WP-0520656-SA	10	17	225-26677	42	31	229-34301	36	40	236-28902	18	33
WP-0531001-SC	38	22	225-28152	24	3	229-34400	36	41	236-29009	18	34
WP-0621016-SD	12	44	225-28350	22	9	229-34509	36	42	236-29306	28	8
WP-0621016-SH	30	52	225-28509	22	6	229-34608	36	37	236-29405	28	9
WP-0621036-SP	14	40	225-28616	24	17	229-40654	16	73	236-29405	28	20
WP-0650876-SD	36	23	225-29002	2	17	229-49002	30	7	236-29801	28	4
WP-0651056-SD	2	40	225-29101	2	18	229-49101	30	8	236-29801	28	12
WP-0661016-SP	14	19	225-29200	2	19	229-52501	16	12	236-29801	28	16
WP-0720516-SD	8	59	225-29473	6	26	229-55900	32	19	236-29900	2	11
WP-0740516-SP	12	11	225-29481	6	25	229-56007	32	20	236-30007	28	14
WP-0820526-SD	12	6	225-35801	42	1	229-56205	32	21	236-30007	28	15
WP-0820526-SD	14	13	225-35900	42	3	229-56304	32	22	236-30007	28	17
WP-1612616-SE	38	15	225-36403	42	4	229-57104	32	24	236-30007	28	18
WS-0270002-KN	30	34	225-36502	40	7	229-57203	32	25	236-30007	28	23
WS-0310702-KS	42	26	225-36502	42	5	229-58003	40	13	236-30007	28	28
WS-0510002-KN	38	21	225-54505	30	9	229-58052	40	11	236-30106	28	6
WZ-0641510-KP	2	39	225-54802	30	12	229-58300	40	9	236-30106	28	19
			225-54901	30	13	235-02958	42	57	236-30601	28	22
100-01709	2	31	225-55304	30	14	235-03006	42	61	236-30650	28	21
100-06005	24	7	225-55551	30	15	235-03303	42	82	236-39107	36	9
100-08753	8	13	225-55858	30	16	235-03402	18	16	236-39156	36	8
100-25906	40	25	225-56054	42	11	235-03501	42	37	236-39206	36	12
100-25906	42	28	225-56153	42	20	235-03501	42	50	236-39305	36	13
100-31003	18	6	225-56302	42	12	235-03659	42	56	236-39404	36	14
100-33009	42	38	225-56450	42	13	235-03709	42	58	236-39503	36	15
100-33009	42	51	225-56609	42	14	235-03808	42	59	236-39602	36	16
100-33108	42	40	225-56708	42	15	235-03907	42	60	236-39701	40	4
100-33108	42	53	225-56807	42	16	235-04004	42	62	260-25106	4	22
100-61554	42	84	225-56906	30	17	235-04103	42	63	262-01004	22	22
100-64004	42	87	225-57458	30	18	235-04301	42	64	262-34005	40	17
101-62600	36	5	225-57557	30	21	235-04400	42	65	263-00103	4	14
110-01609	4	11	225-57706	30	22	235-04657	42	66	263-03107	16	72
110-15906	18	20	225-57805	30	23	235-22550	42	46	263-03404	16	23
110-40854	30	6	225-57904	30	24	235-23004	42	47	263-05300	2	35
110-47107	36	4	225-58001	30	27	235-23152	42	48	263-05409	2	28
110-50705	16	7	225-58100	30	28	235-23202	42	52	263-14757	4	10
110-72402	6	27	225-58159	30	26	235-26601	4	2	293-42409	40	18
110-93606	6	30	225-58209	30	25	235-26809	4	4			
111-62104	42	21	225-58308	30	19	235-27906	8	1	400-00343	28	11
182-00501	12	45	225-58407	30	20	235-28102	8	12	400-00344	28	7
198-00903	42	71	225-62201	32	17	235-28706	8	30	400-03590	18	2
198-01000	42	72	225-81508	16	47	235-28755	8	29	400-03618	8	53
198-01109	42	74	225-82407	4	7	235-29100	8	42	400-06323	40	21
198-01208	42	75	225-84965	12	46	235-29159	8	41	400-08118	10	10
198-01307	42	73	225-86705	42	2	235-29209	8	43	400-08119	10	11
198-01406	42	76	225-91564	42	86	235-29308	8	44	400-08120	10	12
198-01505	42	77	225-96704	18	15	235-29407	8	46	400-08121	10	13
198-01604	42	78	225-96704	40	2	235-29506	8	45	400-08168	42	83
			228-90008	18	11	235-31114	8	55	400-08169	10	19
225-02504	40	10	228-91204	6	2	235-32005	16	28	400-08169	16	44
225-03353	42	45	229-01805	4	16	235-32203	16	26	400-10278	10	7
225-03908	40	22	229-07109	12	18	235-32401	16	50	400-10278	16	38
225-03908	42	29	229-07109	14	14	235-35107	18	1	400-10281	8	27
225-05705	8	17	229-07406	12	17	235-35602	18	3	400-10282	18	29
225-06208	8	16	229-07604	12	14	235-36055	20	3	400-10283	18	4
225-07404	8	37	229-07703	12	15	235-36105	20	4	400-10286	10	20
225-07701	8	35	229-07802	12	9	235-36253	20	5	400-10286	16	40
225-07701	42	44	229-08156	12	28	235-38309	24	4	400-10286	16	60
225-08006	8	25	229-08552	12	10	235-38606	26	3	400-10287	10	21
225-24201	42	79	229-08701	12	32	235-39414	28	3	400-10287	16	41
225-24805	42	80	229-12307	16	10	235-41709	20	17	400-10287	16	61
225-25059	42	30	229-16506	18	21	235-41808	30	5	400-10288	10	22

NUMERICAL INDEX OF PARTS

索引

PART NO 品番	PAGE 頁	REF NO	PART NO 品番	PAGE 頁	REF NO	PART NO 品番	PAGE 頁	REF NO	PART NO 品番	PAGE 頁	REF NO
400-10288	16	42	401-25710	4	35	401-91114	6	16	402-26004	14	7
400-10288	16	62	401-26724	22	5	401-91115	6	17	402-26006	14	3
400-10289	10	23	401-36292	6	31	401-91116	6	18	402-26007	14	4
400-10289	16	43	401-38514	12	41	401-91349	36	24	402-26008	14	20
400-10289	16	63	401-39216	16	18	401-96122	32	23	402-26009	14	38
400-10290	30	1	401-41101	24	5	402-00004	14	9	402-26010	14	21
400-10295	30	11	401-41757	14	39	402-08472	4	31	402-26014	14	22
400-10296	8	51	401-49246	16	49	402-08473	4	29	402-26017	14	2
400-10297	8	49	401-49251	20	7	402-08474	4	32	402-26018	14	16
400-10298	10	14	401-49252	20	8	402-08490	4	39	402-26019	14	17
400-10303	20	6	401-49253	20	9	402-09310	12	24	402-26020	14	24
400-10311	16	17	401-49254	20	10	402-09310	14	26	402-26021	14	15
400-10314	20	2	401-50131	4	36	402-09311	2	6	402-40053	40	27
400-10315	8	56	401-60261	8	23	402-09312	10	5	402-40056	40	28
400-10316	20	1	401-60262	20	20	402-09314	28	1	402-50030	40	26
400-10318	16	25	401-66870	6	3	402-09315	28	2	402-54811	22	7
400-10321	26	2	401-66872	6	4	402-09316	16	88			
400-10322	8	57	401-66881	6	5	402-09317	16	82			
400-10324	8	2	401-66885	6	6	402-09318	2	4			
400-11345	4	1	401-66886	6	7	402-09318	16	79			
400-11424	18	13	401-66887	6	8	402-09319	18	5			
400-11837	16	29	401-66888	6	9	402-09320	20	24			
400-16408	42	70	401-66893	6	10	402-09322	36	3			
400-21606	32	5	401-66894	6	11	402-09323	36	1			
400-22407	10	25	401-68921	16	35	402-09325	32	9			
400-22407	12	34	401-68922	16	78	402-09328	22	1			
400-22407	14	33	401-68923	12	35	402-09330	12	29			
400-24644	4	27	401-68923	14	34	402-09331	22	25			
400-28294	4	21	401-69398	34	8	402-09331	24	22			
400-28463	4	3	401-72146	8	18	402-09332	12	4			
400-32271	16	21	401-72366	2	8	402-09333	12	1			
400-35589	4	34	401-72375	4	47	402-09335	2	24			
400-36706	12	42	401-72377	8	10	402-09336	22	11			
400-37008	6	32	401-72378	16	1	402-09339	22	10			
400-38494	16	16	401-72386	34	4	402-09341	8	62			
400-50457	16	22	401-72389	14	32	402-09342	12	30			
400-56873	8	33	401-72393	8	7	402-09343	12	36			
400-70532	8	32	401-72398	8	6	402-09343	14	35			
400-85784	38	2	401-72401	12	2	402-09344	18	30			
400-85785	38	3	401-72402	12	7	402-09345	18	31			
400-85786	38	4	401-72402	14	11	402-09347	24	18			
400-85787	38	5	401-72415	12	25	402-09348	2	37			
400-85788	38	6	401-72415	14	27	402-09349	2	33			
400-85789	38	7	401-72418	8	9	402-09350	32	1			
400-85790	38	8	401-72420	34	5	402-09352	4	20			
400-85791	38	9	401-72422	34	6	402-09353	22	18			
400-85792	38	10	401-72423	34	7	402-09355	16	85			
400-85793	38	11	401-72472	22	12	402-09356	16	32			
400-85794	38	12	401-72473	22	14	402-09416	24	15			
400-85795	38	13	401-72474	22	8	402-11903	12	26			
400-85796	38	16	401-72475	22	19	402-11903	14	28			
400-86606	12	19	401-72509	16	5	402-13295	4	9			
400-86607	12	20	401-72510	16	6	402-15736	40	1			
400-86699	16	87	401-73451	34	2	402-15739	32	26			
400-91888	42	85	401-73459	34	3	402-16994	2	2			
400-94561	4	48	401-74291	16	3	402-18924	36	6			
400-96325	38	14	401-74293	16	8	402-19867	10	2			
400-96326	38	17	401-74294	16	9	402-19875	4	33			
400-96327	38	19	401-74311	22	20	402-19941	10	1			
400-96354	38	1	401-74322	2	23	402-19946	36	2			
401-20730	18	28	401-74375	12	38	402-19949	2	1			
401-25433	2	26	401-74388	12	5	402-19970	34	1			
401-25438	4	30	401-74405	16	14	402-19976	28	31			
401-25469	12	22	401-74408	34	13	402-19977	36	32			
401-25481	16	69	401-74570	40	8	402-19979	36	7			
401-25483	16	71	401-74580	34	10	402-19990	30	10			
401-25485	16	70	401-74615	12	3	402-19991	32	18			
401-25487	16	52	401-75585	34	14	402-19992	22	24			
401-25488	16	53	401-88608	4	40	402-19992	24	21			
401-25507	18	14	401-89389	4	18	402-19993	26	1			
401-25645	32	16	401-91107	6	1	402-19999	36	35			
401-25647	32	8	401-91108	6	12	402-20000	16	90			
401-25651	24	1	401-91109	6	13	402-21270	28	29			
401-25685	22	17	401-91111	6	14	402-21271	28	30			
401-25685	24	14	401-91113	6	15	402-26003	14	6			